



Precision Meets Perfection,  
Economical Solutions.



2024

# Euro Style Press Brake Catalog

Visit us: [www.ketecooling.com](http://www.ketecooling.com)



“  
Precision  
Meets  
Perfection,  
Economical  
Solutions.  
”

# About Us

## Innovative Solutions for Fabrication Challenges

Founded in 1998, KETEC Precision Tooling is the **largest manufacturer of Punch Press and Press Brake tooling in China and Asia.**

With over 25 years of unremitting efforts in product innovation and development, as well as manufacturing refinement - In 2010, our Punch Press and Press Brake tools were appointed by the government as the industrial standard in China. As the leader of CNC tooling for the sheet metal fabrication industry. Our products have always been well-known **high-quality, customer-centric, and cost-effective.**

## Empowering Metal Fabricators with Top-notch Tooling Solutions

Staying competitive in the manufacturing industry means having better flexibility, quality and efficiency while maintaining a sustainable profit.

That's why many manufacturers choose us. Through our unwavering commitment to quality control, refined manufacturing processes, and consultative customer service, we partner with our customers to minimize costs, boost revenue, and sustain their competitive edge.



# Milestones

## 2004

### Obtained Certifications

KETEC®'s trademark was registered as an international trademark and obtained ISO certification - **ISO9000:2000**.



## 2008

### Equipped with High Capacity

Experienced tremendous growth and built our current manufacturing facilities **encompassing a total of 13 acres** in Conghua, Guangzhou, China.



## 2010

### Became National Standard

The National Standardization Committee of China **commissioned KETEC to draft the standard** for "Tooling for CNC Turret Punch Machine." In July of the same year, the Ministry of Industry and IT of China issued and implemented the standard **JB/T10928-2010** for "CNC Turret Punch Press Tooling."



## 2012

### Largest in Asia

KETEC became the **largest exporter by volume** and manufacturer of CNC sheet metal tooling in Asia with an annual revenue of **\$45 Million USD**.



## 2020

### Customer Centric

Implemented both **ERP and CRM software** company-wide to better serve our customers.



# Official OEMS Partners



# Customer Highlight



# KETEC Agents

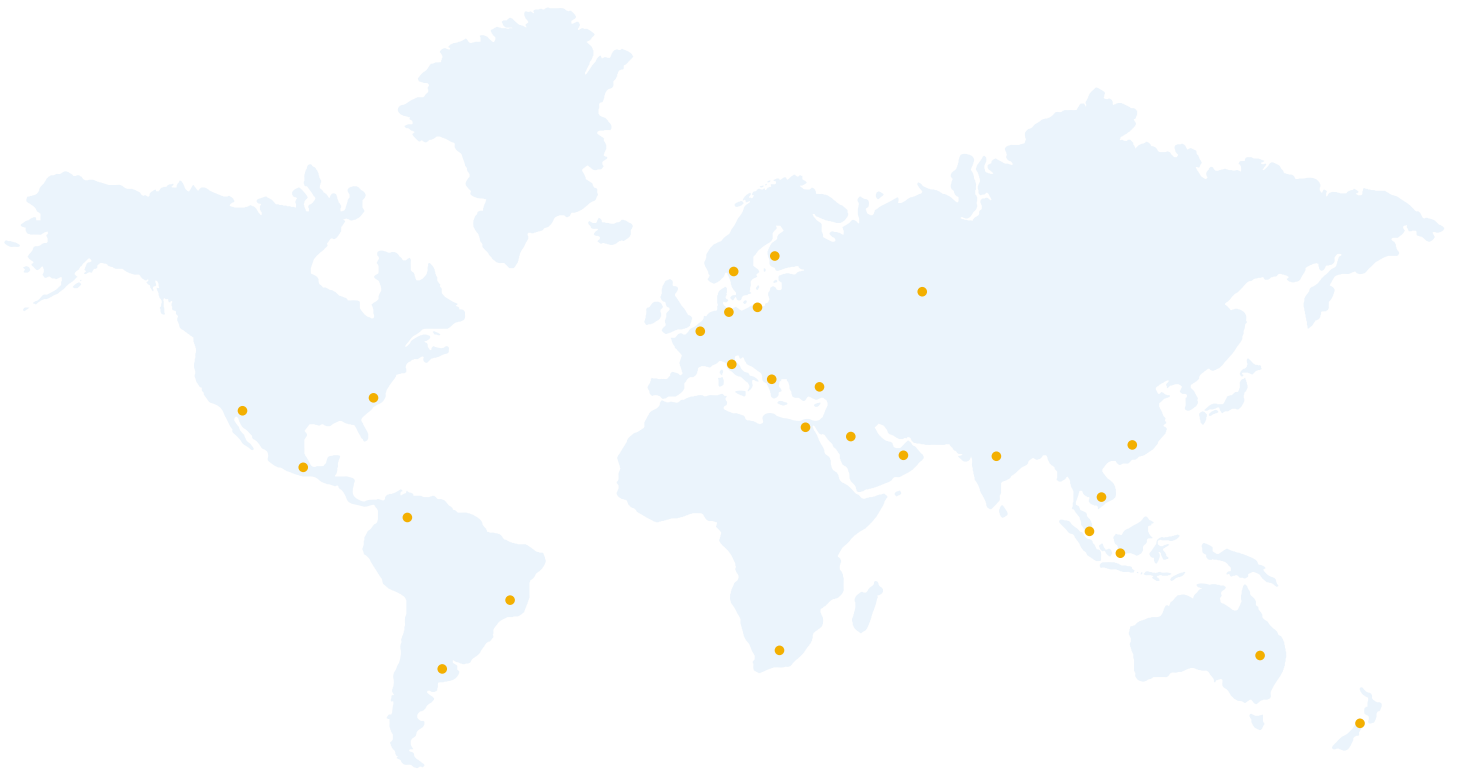

**Our agents are established in more than 25 countries worldwide**



# Facilities Gallery

## Ordering Workshop



## Heat-Treatment Center



## Standard Production Line



## Customized Line



## Tooling Test Center



## Quality Control Lab

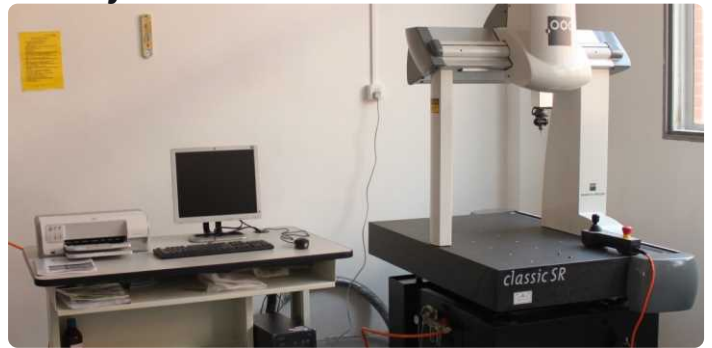

# Product Offerings

We specialize in sheet metal fabrication tooling, including **Punch Press, Press Brake, Stamping tools and related machines.**

## Punch Press Tooling

- Thick Turret Tooling
- Thin Turret Tooling
- TRUMPF® Style Tooling
- Salvagnini®
- Muratec-Wiedemann®



## Stamping Tools

- Automotive
- Thick Plate
- Copper Plate



## Press Brake Tooling

- Euro-Amada® Style
- Wila®-Trumpf® Style



## Machines

- Tool Grinding Machine
- 2D Inspection Machine



# Table of Contents

## KETEC PRESS BRAKE TOOLING - PUNCH PART

TOOL SELECTION GUIDE TABLE	10
KETEC BENDING TOOLS INTRODUCTION	11
PRESS TOOLING INDEX - PUNCHES	12
SASH PUNCH	13-14
ACUTE PUNCH	15
STRAIGHT PUNCH	16
GOOSENECK PUNCH	17-18
STANDARD PUNCH	19
BURRING PUNCH	20-21
HEMMING PUNCH	22
FLATTENING PUNCH	23
RADIUS PUNCH	24
OFFSET TOOLS	25
EURO-AMADA STYLE DIE	
STANDARD LENGTHS & SEGMENTAL	26
PRESS BRAKE TOOLING DIE INDEX	27
PRESS BRAKE TOOLING 1V DIE	28
CONCENTRIC 1V DIE	29
HEAVY GAUGE 1V DIE	30-31
BOLT-ON 1V DIE	32-33
SLOT 1V DIE	34-41
PRESS BRAKE TOOLING 2V DIE	42
CONCENTRIC 2V DIE	43-51
BOLT-ON 2V DIE	55-58
HEMMING DIE	60-61
ACCESSORIES	62-64
PRESS BRAKE MAINTENANCE GUIDANCE	65-67



# European Style Press Brake

## European Precision Style

Ketec's European Precision Style press brake tools are made with premium alloy with in-house heat treatment and laser hardening, Making it forever-lasting for any metal bending application. We offer press brake punches, dies, and accessories in segmented, full-length, and half-length sizes.

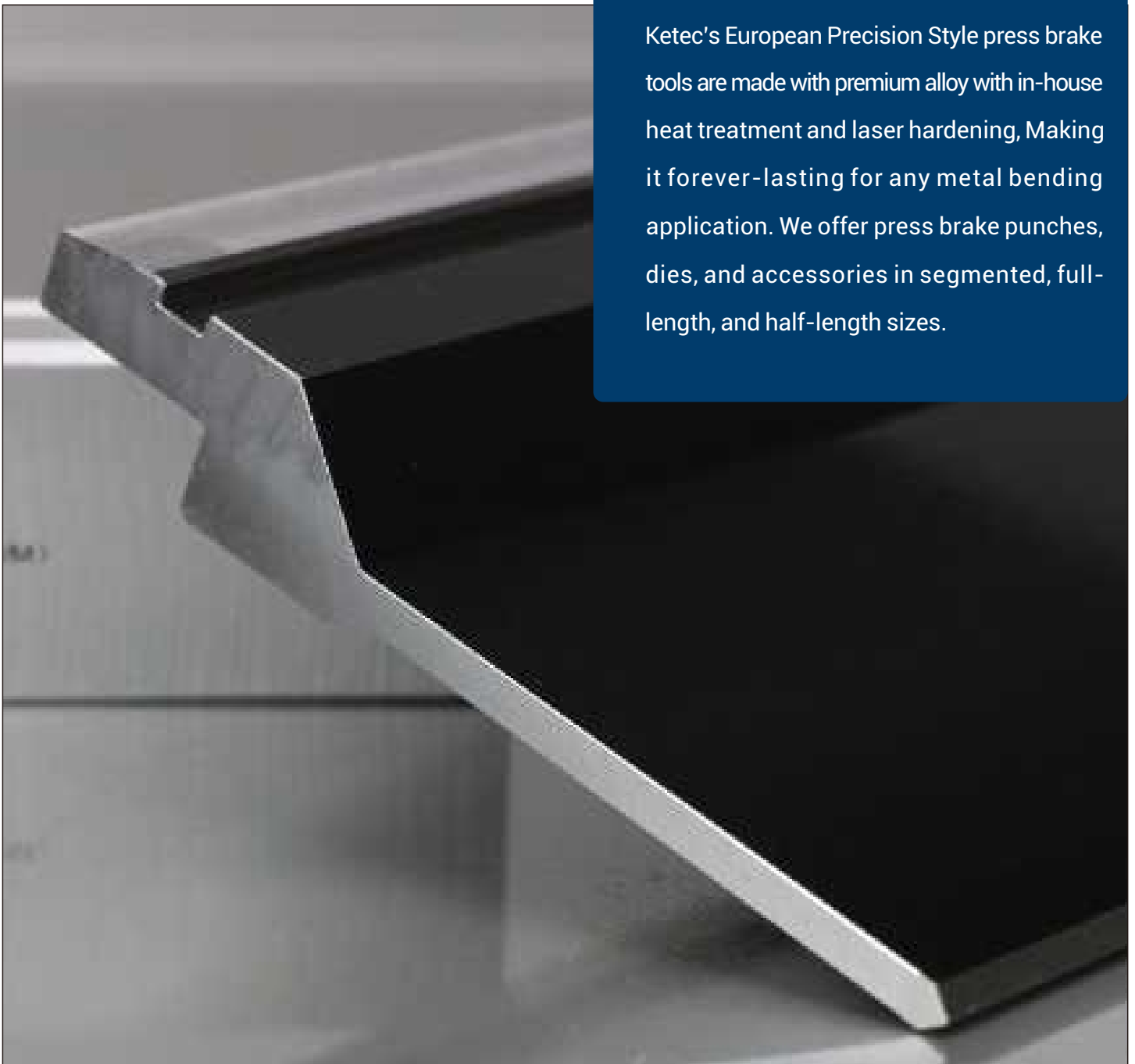



# EUROPEAN PRECISION STYLE

## TOOL SELECTION GUIDE TABLE



**GOOSENECK BEND 90°**      **GOOSENECK DEEP BEND 90°**      **STRAIGHT BEND 90°**      **REVERSIBLE BEND 90°**

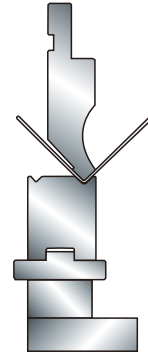
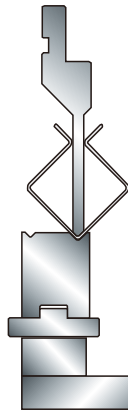
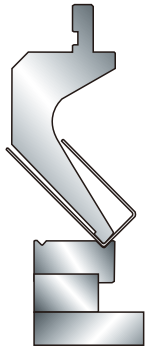
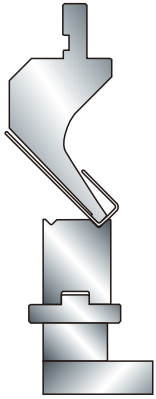

**STANDARD BEND 90°**      **SASH BEND 90°**      **HEAVY GAUGE ACUTE BEND**      **HEAVY GAUGE BEND 90°**

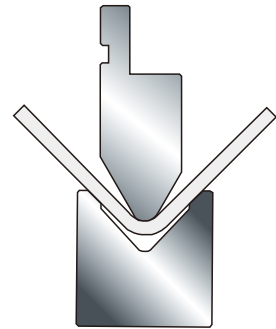
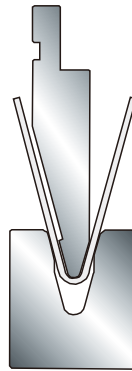
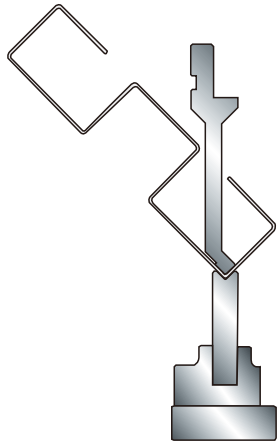
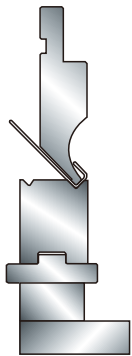

**V AND HEMMING BEND**      **HEMMING BEND**      **OFFSET BEND**      **RADIUS BEND**

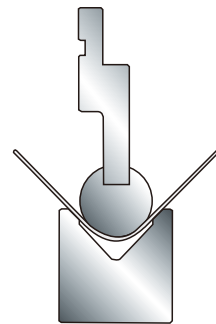
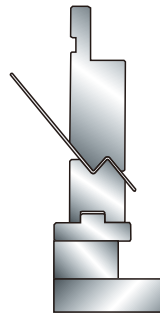
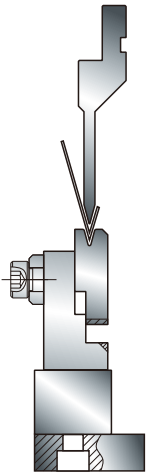

**Overview**

Inheriting the excellent qualities of Ketec's punch press tooling, Ketec press brake tooling uses premium 42CrMo, and incorporates the most advanced processing and heat treatment technologies. All key dimensions achieve a precision of  $\pm 0.01$  mm, providing you with optimal bending performance.

• **Capability**

In 2010, Ketec's new factory, covering 13 acres, was established to specialize in press brake tooling with an annual production capacity of 50,000 units (standard sections).

• **Precision**

All contacting surfaces of our toolings are formed in a single process, ensuring that the height, angle, and radius of the same model are perfectly consistent. Key dimensions maintain a precision of  $\pm 0.01$  mm, guaranteeing assembly accuracy remains unchanged regardless of when the tool is purchased.

• **Interchangeability**

All of our tooling are interchangeable and will perfectly match with other mainstream manufacturers, to eliminates the need for secondary adjustments to correct errors, saving time during tool changes

• **Durability**

All compression and wear areas are treated with laser hardening & heat treatment to 56-60 HRC to meet extreme tolerances and complex requirements.

**Tooling Information Label**

	#501861    88° 2V4-7 H=45.5    L=100	MAX: 600KN/M (60ton/m) MAX: 18TON/FOOT <a href="http://www.ketecooling.com">www.ketecooling.com</a>
--	--	---

**European Clamping Style**

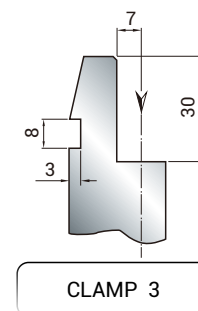
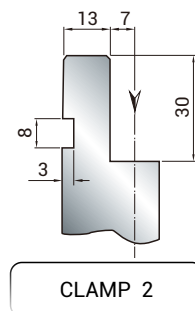
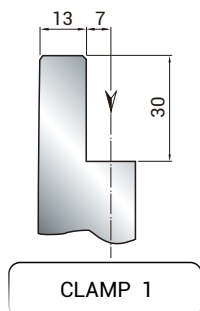



# EUROPEAN PRECISION STYLE

## PRESS TOOLING INDEX - PUNCHES



PUNCHES  
INDEX

SASH PUNCHES	ACUTE PUNCHES	STRAIGHT PUNCHES	GOOSENECK PUNCHES	STANDARD PUNCHES
--------------	---------------	------------------	-------------------	------------------



BURRING PUNCHES	HEMMING PUNCHES	FLATTENING PUNCHES	FLATTENING PUNCHES	RADIUS PUNCH HOLDER
-----------------	-----------------	--------------------	--------------------	---------------------

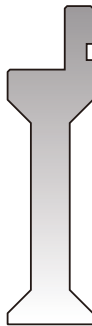

RADIUS PUNCH HOLDER	RADIUS PUNCH HOLDER	RADIUS TIPS	RADIUS TIPS	RADIUS TIPS
---------------------	---------------------	-------------	-------------	-------------



Ø40



Ø50

RADIUS TIPS	RADIUS TIPS	OFFSET BENDING TOOL SET	OFFSET BENDING TOOL SET	OFFSET BENDING TOOL SET
-------------	-------------	-------------------------	-------------------------	-------------------------

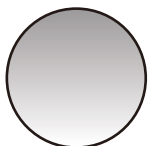

Ø60

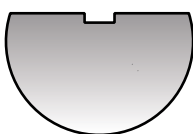

Ø80

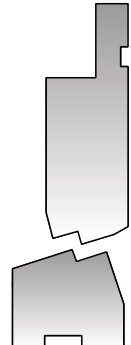
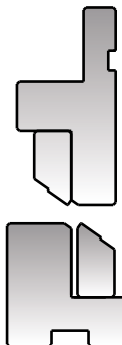

Fixed Height / H=85

A14

Fixed Height / H=85

A10

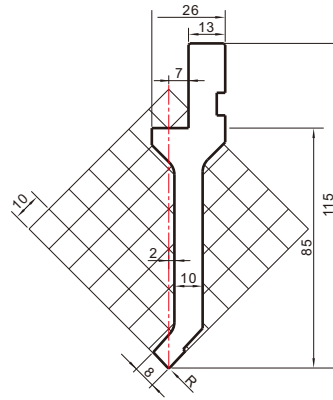
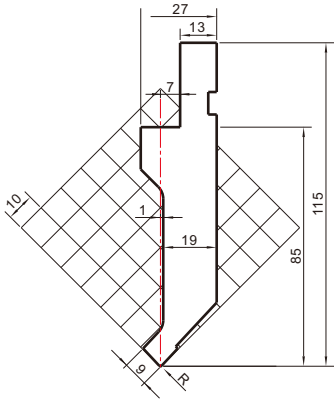

Config.	Length	Weight		Tip		Max Load
		kg	lbs	Angle	Radius	
Non-sectioned	835mm/32.874"	12.7	28.00	86°	R0.6	100t/m. 30.48t/ft.
Sectioned						
Non-sectioned	415mm/16.339"	6.3	13.90	86°	R0.6	30t/m. 9.14t/ft.
Sectioned						
Customizable	Yes					
Material	42CrMo					
Laser Hardening	Yes					
Black Oxidation	Yes					

Config.	Length	Weight		Tip		Max Load
		kg	lbs	Angle	Radius	
Non-sectioned	835mm/32.874"	8.7	19.18	86°	R0.6	30t/m. 9.14t/ft.
Sectioned						
Non-sectioned	415mm/16.339"	4	8.82	86°	R0.6	30t/m. 9.14t/ft.
Sectioned						
Customizable	Yes					
Material	42CrMo					
Laser Hardening	Yes					
Black Oxidation	Yes					

Fixed Height / H=120

A200

Fixed Height / H=120

A200 (6\*6)

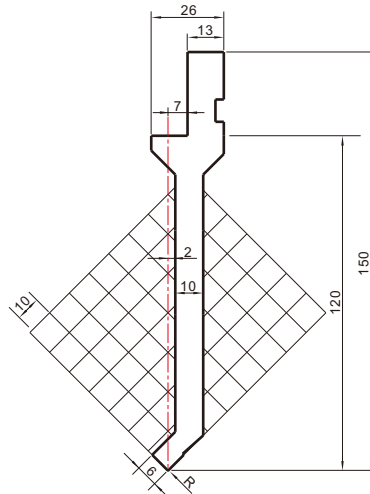
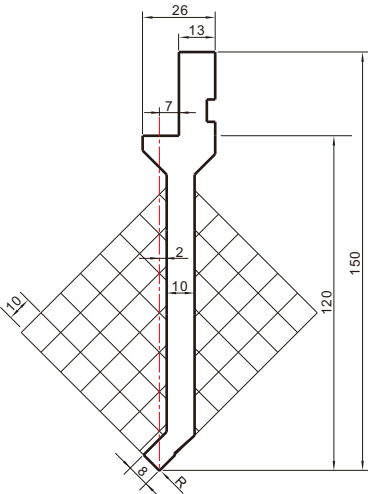

Config.	Length	Weight		Tip		Max Load
		kg	lbs	Angle	Radius	
Non-sectioned	835mm/32.874"	11	24.25	86°	R0.6	45t/m. 13.72t/ft.
Sectioned						
Non-sectioned	415mm/16.339"	5.5	12.13	86°	R0.6	30t/m. 9.14t/ft.
Sectioned						
Customizable	Yes					
Material	42CrMo					
Laser Hardening	Yes					
Black Oxidation	Yes					

Config.	Length	Weight		Tip		Max Load
		kg	lbs	Angle	Radius	
Non-sectioned	835mm/32.874"	10.8	23.81	86°	R0.6	30t/m. 9.14t/ft.
Sectioned						
Non-sectioned	415mm/16.339"	5.5	12.13	86°	R0.6	30t/m. 9.14t/ft.
Sectioned						
Customizable	Yes					
Material	42CrMo					
Laser Hardening	Yes					
Black Oxidation	Yes					



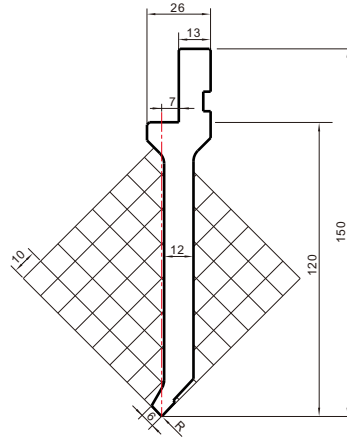
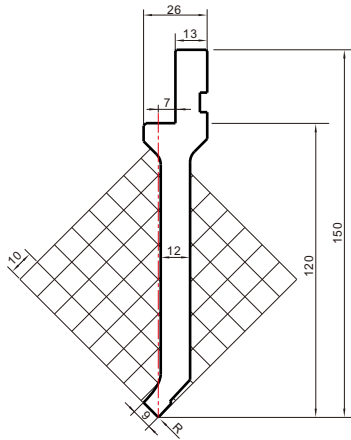

Config.	Length	Weight		Tip		Max Load
		kg	lbs	Angle	Radius	
Non-sectioned	835mm/32.874"	12.5	27.56	86°	R0.6	100t/m. 30.48t/ft.
Sectioned						
Non-sectioned	415mm/16.339"	6.2	13.67	86°	R0.6	100t/m. 30.48t/ft.
Sectioned						
Customizable	Yes					
Material	42CrMo					
Laser Hardening	Yes					
Black Oxidation	Yes					

Config.	Length	Weight		Tip		Max Load
		kg	lbs	Angle	Radius	
Non-sectioned	835mm/32.874"	12.3	27.12	86°	R0.6	70t/m. 21.34t/ft.
Sectioned						
Non-sectioned	415mm/16.339"	6.2	13.67	86°	R0.6	70t/m. 21.34t/ft.
Sectioned						
Customizable	Yes					
Material	42CrMo					
Laser Hardening	Yes					
Black Oxidation	Yes					

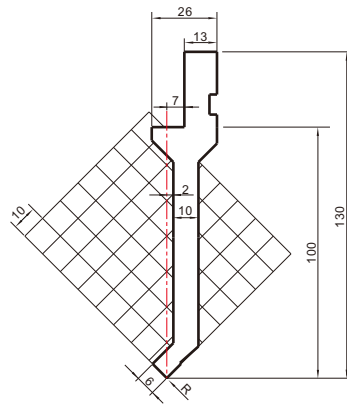
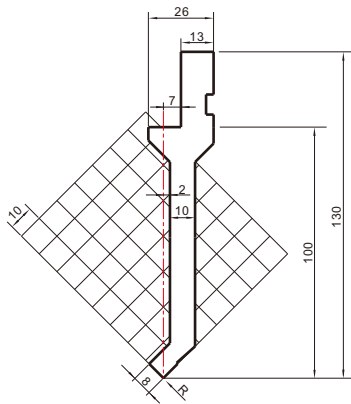

Config.	Length	Weight		Tip		Max Load
		kg	lbs	Angle	Radius	
Non-sectioned	835mm/32.874"	9.7	21.38	88°	R0.6	30t/m. 9.14t/ft.
Sectioned						
Non-sectioned	415mm/16.339"	4.8	10.58	88°	R0.6	30t/m. 9.14t/ft.
Sectioned						
Customizable	Yes					
Material	42CrMo					
Laser Hardening	Yes					
Black Oxidation	Yes					

Config.	Length	Weight		Tip		Max Load
		kg	lbs	Angle	Radius	
Non-sectioned	835mm/32.874"	9.5	20.94	88°	R0.6	25t/m. 7.62t/ft.
Sectioned						
Non-sectioned	415mm/16.339"	4.75	10.47	88°	R0.6	25t/m. 7.62t/ft.
Sectioned						
Customizable	Yes					
Material	42CrMo					
Laser Hardening	Yes					
Black Oxidation	Yes					

SASH PUNCH  
86°/88°

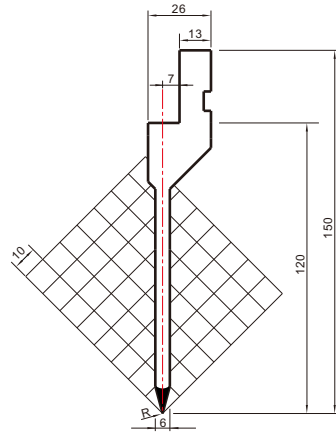
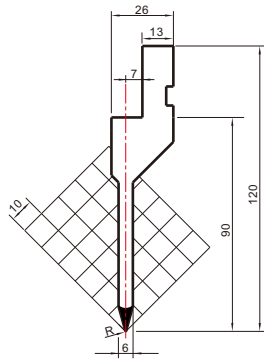

Config.	Length	Weight		Tip		Max Load
		kg	lbs	Angle	Radius	
Non-sectioned	835mm/32.874"	8.4	18.52	86°	R0.6	45t/m. 13.72t/ft.
Sectioned						
Non-sectioned	415mm/16.339"	4.2	9.26	86°	R0.6	45t/m. 13.72t/ft.
Sectioned						
Customizable	Yes					
Material	42CrMo					
Laser Hardening	Yes					
Black Oxidation	Yes					

Config.	Length	Weight		Tip		Max Load
		kg	lbs	Angle	Radius	
Non-sectioned	835mm/32.874"	9.4	20.72	30°	R0.6	45t/m. 13.72t/ft.
Sectioned						
Non-sectioned	415mm/16.339"	4.7	10.36	30°	R0.6	45t/m. 13.72t/ft.
Sectioned						
Customizable	Yes					
Material	42CrMo					
Laser Hardening	Yes					
Black Oxidation	Yes					

Fixed Height / H=120

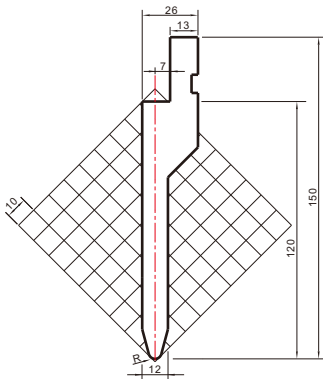

Config.	Length	Weight		Tip		Max Load
		kg	lbs	Angle	Radius	
Non-sectioned	835mm/32.874"	14	30.86	30°	R3.0	50t/m. 15.24t/ft.
Sectioned						
Non-sectioned	415mm/16.339"	7	15.43	30°	R3.0	50t/m. 15.24t/ft.
Sectioned						
Customizable	Yes					
Material	42CrMo					
Laser Hardening	Yes					
Black Oxidation	Yes					

Fixed Height / H=85

A29

Fixed Height / H=120

A190

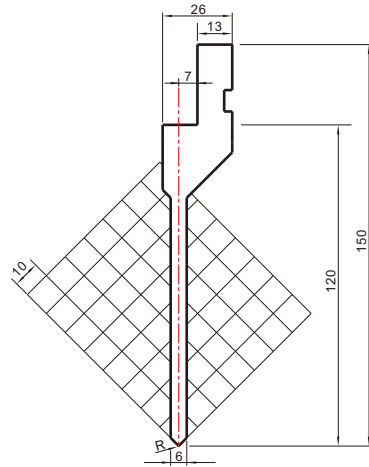
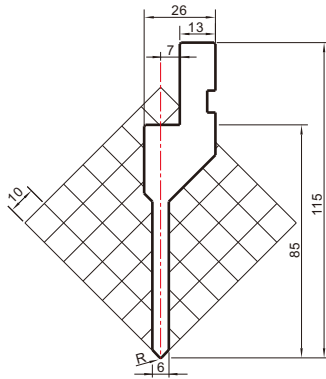

STRAIGHT PUNCH

86° / 88°

Config.	Length	Weight		Tip		Max Load
		kg	lbs	Angle	Radius	
Non-sectioned	835mm/32.874"	8.8	19.40	86°	R0.6	50t/m. 15.24t/ft.
Sectioned						
Non-sectioned	415mm/16.339"	4.4	9.70	86°	R0.6	50t/m. 15.24t/ft.
Sectioned						
Customizable	Yes					
Material	42CrMo					
Laser Hardening	Yes					
Black Oxidation	Yes					

Config.	Length	Weight		Tip		Max Load
		kg	lbs	Angle	Radius	
Non-sectioned	835mm/32.874"	8.7	19.18	86°	R0.6	45t/m. 13.72t/ft.
Sectioned						
Non-sectioned	415mm/16.339"	4	8.82	86°	R0.6	45t/m. 13.72t/ft.
Sectioned						
Customizable	Yes					
Material	42CrMo					
Laser Hardening	Yes					
Black Oxidation	Yes					

H=95

109

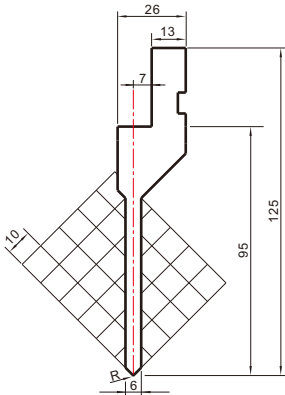

Config.	Length	Weight		Tip		Max Load
		kg	lbs	Angle	Radius	
Non-sectioned	835mm/32.874"	8.8	19.40	88°	R0.6	50t/m. 15.24t/ft.
Sectioned						
Non-sectioned	415mm/16.339"	4.4	9.70	88°	R0.6	50t/m. 15.24t/ft.
Sectioned						
Customizable	Yes					
Material	42CrMo					
Laser Hardening	Yes					
Black Oxidation	Yes					

Fixed Height / H=85

A43

Fixed Height / H=120

A47(6\*6)

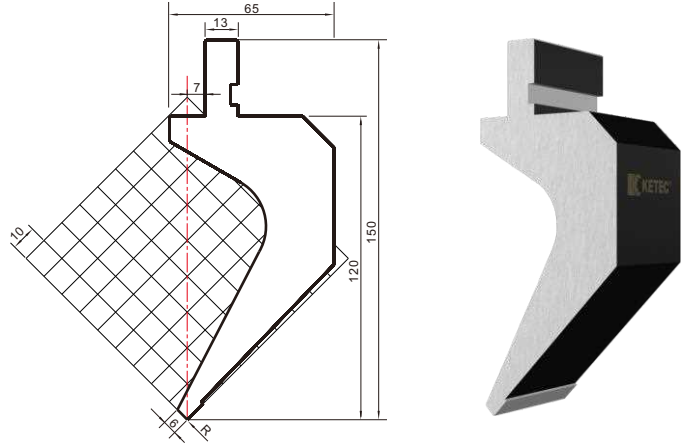
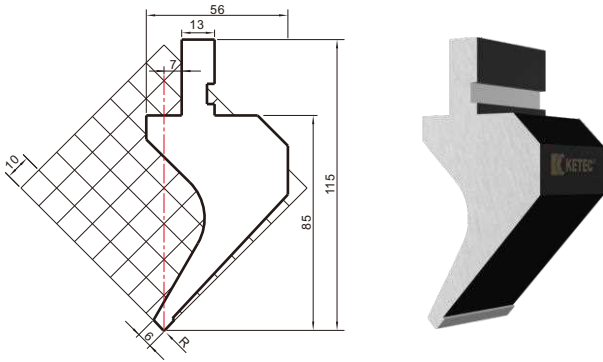

Config.	Length	Weight		Tip		Max Load
		kg	lbs	Angle	Radius	
Non-sectioned	835mm/32.874"	18	39.68	86°	R0.6	50t/m. 15.24t/ft.
Sectioned						
Non-sectioned	415mm/16.339"	9	19.84	86°	R0.6	50t/m. 15.24t/ft.
Sectioned						
Customizable	Yes					
Material	42CrMo					
Laser Hardening	Yes					
Black Oxidation	Yes					

Config.	Length	Weight		Tip		Max Load
		kg	lbs	Angle	Radius	
Non-sectioned	835mm/32.874"	23.8	52.47	86°	R0.6	30t/m. 9.14t/ft.
Sectioned						
Non-sectioned	415mm/16.339"	11.8	26.01	86°	R0.6	30t/m. 9.14t/ft.
Sectioned						
Customizable	Yes					
Material	42CrMo					
Laser Hardening	Yes					
Black Oxidation	Yes					

Fixed Height / H=120

A47

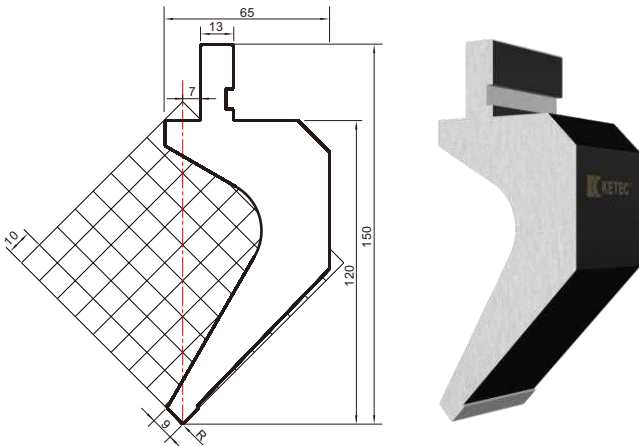

Config.	Length	Weight		Tip		Max Load
		kg	lbs	Angle	Radius	
Non-sectioned	835mm/32.874"	26	57.32	86°	R0.6	50t/m. 15.24t/ft.
Sectioned						
Non-sectioned	415mm/16.339"	13	28.66	86°	R0.6	50t/m. 15.24t/ft.
Sectioned						
Customizable	Yes					
Material	42CrMo					
Laser Hardening	Yes					
Black Oxidation	Yes					

GOOSENECK PUNCH

86°

H=90

453

H=90

452

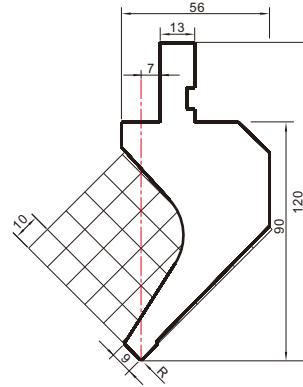
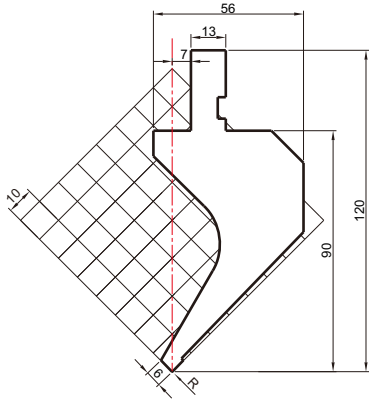

Config.	Length	Weight		Tip		Max Load
		kg	lbs	Angle	Radius	
Non-sectioned	835mm/32.874"	18.6	41.00	88°	R0.6	50t/m. 15.24t/ft.
Sectioned						
Non-sectioned	415mm/16.339"	9.3	20.50	88°	R0.6	50t/m. 15.24t/ft.
Sectioned						
Customizable	Yes					
Material	42CrMo					
Laser Hardening	Yes					
Black Oxidation	Yes					

Config.	Length	Weight		Tip		Max Load
		kg	lbs	Angle	Radius	
Non-sectioned	835mm/32.874"	20	44.09	88°	R0.6	70t/m. 21.34t/ft.
Sectioned						
Non-sectioned	415mm/16.339"	10	20.05	88°	R0.6	70t/m. 21.34t/ft.
Sectioned						
Customizable	Yes					
Material	42CrMo					
Laser Hardening	Yes					
Black Oxidation	Yes					

H=105

045

H=120

047

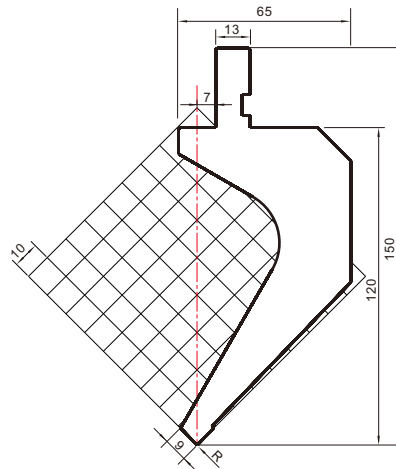
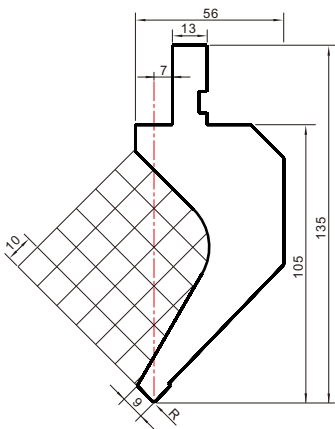

Config.	Length	Weight		Tip		Max Load
		kg	lbs	Angle	Radius	
Non-sectioned	835mm/32.874"	22.3	52.47	88°	R0.6	50t/m. 15.24t/ft.
Sectioned						
Non-sectioned	415mm/16.339"	11	24.25	88°	R0.6	50t/m. 15.24t/ft.
Sectioned						
Customizable	Yes					
Material	42CrMo					
Laser Hardening	Yes					
Black Oxidation	Yes					

Config.	Length	Weight		Tip		Max Load
		kg	lbs	Angle	Radius	
Non-sectioned	835mm/32.874"	26	57.32	88°	R0.6	50t/m. 15.24t/ft.
Sectioned						
Non-sectioned	415mm/16.339"	13	28.66	88°	R0.6	50t/m. 15.24t/ft.
Sectioned						
Customizable	Yes					
Material	42CrMo					
Laser Hardening	Yes					
Black Oxidation	Yes					

GOOSENECK PUNCH

88°



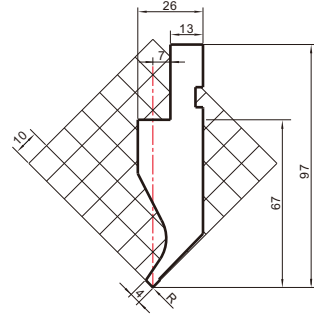
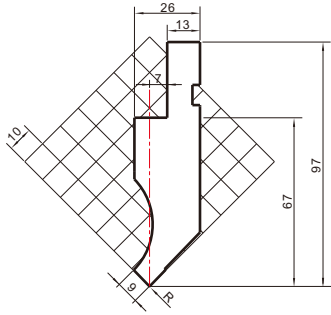

Config.	Length	Weight		Tip		Max Load
		kg	lbs	Angle	Radius	
<b>Non-sectioned</b>	835mm/32.874"	11.2	24.69	88°	R0.6	100t/m. 30.48t/ft.
<b>Sectioned</b>						
<b>Non-sectioned</b>	415mm/16.339"	5.6	12.35	88°	R0.6	20t/m. 6.10t/ft.
<b>Sectioned</b>						
<b>Customizable</b>	Yes					
<b>Material</b>	42CrMo					
<b>Laser Hardening</b>	Yes					
<b>Black Oxidation</b>	Yes					

Config.	Length	Weight		Tip		Max Load
		kg	lbs	Angle	Radius	
<b>Non-sectioned</b>	835mm/32.874"	10.2	22.49	88°	R0.6	20t/m. 6.10t/ft.
<b>Sectioned</b>						
<b>Non-sectioned</b>	415mm/16.339"	5.2	11.46	88°	R0.6	20t/m. 6.10t/ft.
<b>Sectioned</b>						
<b>Customizable</b>	Yes					
<b>Material</b>	42CrMo					
<b>Laser Hardening</b>	Yes					
<b>Black Oxidation</b>	Yes					

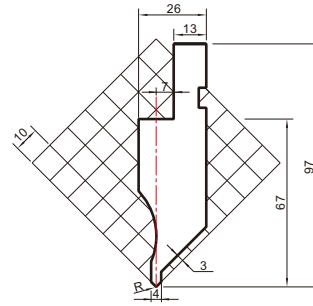
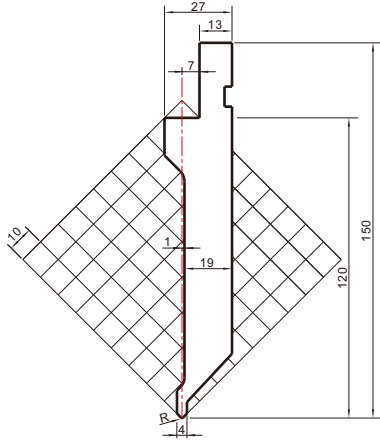

Config.	Length	Weight		Tip		Max Load
		kg	lbs	Angle	Radius	
Non-sectioned	835mm/32.874"	17	37.48	86°	R0.2	40t/m. 12.19t/ft.
Sectioned					R0.6	
Non-sectioned	415mm/16.339"	8.5	18.74	86°	R0.2	40t/m. 12.19t/ft.
Sectioned					R0.6	
Customizable	Yes					
Material	42CrMo					
Laser Hardening	Yes					
Black Oxidation	Yes					

Config.	Length	Weight		Tip		Max Load
		kg	lbs	Angle	Radius	
Non-sectioned	835mm/32.874"	10.5	23.14	88°	R0.2	40t/m. 12.19t/ft.
Sectioned					R0.6	
Non-sectioned	415mm/16.339"	5.2	11.46	88°	R0.2	40t/m. 12.19t/ft.
Sectioned					R0.6	
Customizable	Yes					
Material	42CrMo					
Laser Hardening	Yes					
Black Oxidation	Yes					

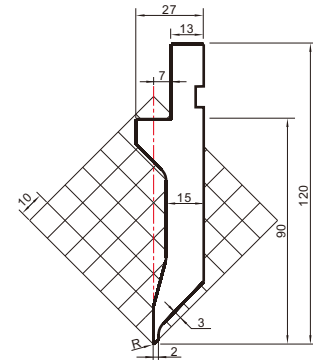
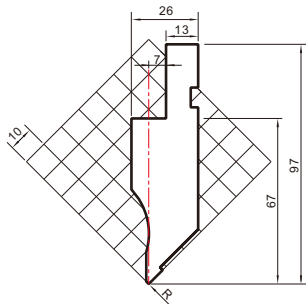

Config.	Length	Weight		Tip		Max Load
		kg	lbs	Angle	Radius	
Non-sectioned	835mm/32.874"	10.5	23.14	88°	R0.2	80t/m. 24.38t/ft.
Sectioned					R0.6	
Non-sectioned	415mm/16.339"	5.2	11.46	88°	R0.2	40t/m. 12.19t/ft.
Sectioned					R0.6	
Customizable	Yes					
Material	42CrMo					
Laser Hardening	Yes					
Black Oxidation	Yes					

Config.	Length	Weight		Tip		Max Load
		kg	lbs	Angle	Radius	
Non-sectioned	835mm/32.874"	11	24.25	88°	R0.2	40t/m. 12.19t/ft.
Sectioned					R0.2	
Non-sectioned	415mm/16.339"	5.5	12.12	88°	R0.2	40t/m. 12.19t/ft.
Sectioned					R0.2	
Customizable	Yes					
Material	42CrMo					
Laser Hardening	Yes					
Black Oxidation	Yes					

BURRING PUNCH

86° / 88°

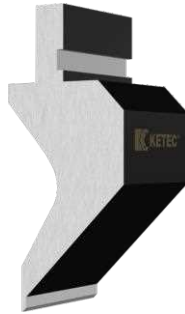
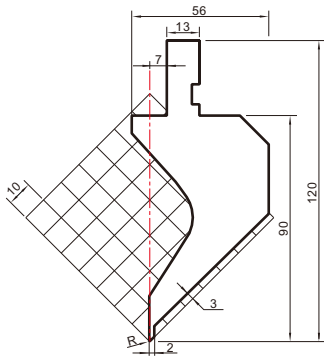

Config.	Length	Weight		Tip		Max Load
		kg	lbs	Angle	Radius	
<b>Non-sectioned</b>	835mm/32.874"	18.4	40.56	88°	R0.2	40t/m. 12.19t/ft.
<b>Sectioned</b>						
<b>Non-sectioned</b>	415mm/16.339"	9	19.84	88°	R0.2	40t/m. 12.19t/ft.
<b>Sectioned</b>						
<b>Customizable</b>	Yes					
<b>Material</b>	42CrMo					
<b>Laser Hardening</b>	Yes					
<b>Black Oxidation</b>	Yes					

H=120

210

Fixed Height / H=120

L210

HEMMING PUNCH

26° / 30°

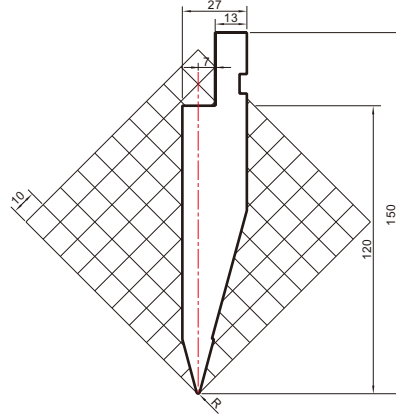
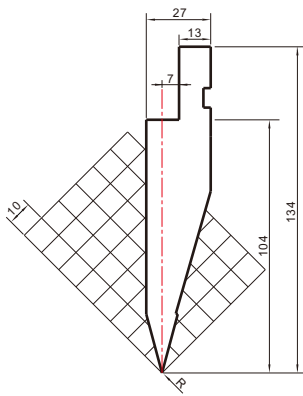

Config.	Length	Weight		Tip		Max Load
		kg	lbs	Angle	Radius	
Non-sectioned	835mm/32.874"	15	33.07	26°	R0.65	100t/m. 30.48t/ft.
Sectioned					R1.0	
Non-sectioned	415mm/16.339"	7.5	16.53	30°	R1.0	100t/m. 30.48t/ft.
Sectioned					R1.0	
Customizable	Yes					
Material	42CrMo					
Laser Hardening	Yes					
Black Oxidation	Yes					

Config.	Length	Weight		Tip		Max Load
		kg	lbs	Angle	Radius	
Non-sectioned	835mm/32.874"	18	39.68	26°	R0.65	100t/m. 30.48t/ft.
Sectioned					R1.0	
Non-sectioned	415mm/16.339"	9	19.84	30°	R1.0	100t/m. 30.48t/ft.
Sectioned					R1.0	
Customizable	Yes					
Material	42CrMo					
Laser Hardening	Yes					
Black Oxidation	Yes					

Hemming Punch H=65.5

103

Fixed Height / H=85

A23

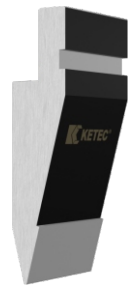
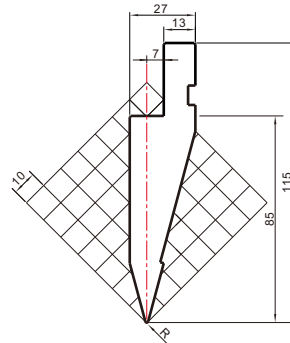
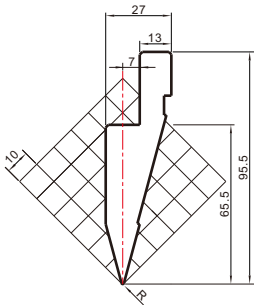

Config.	Length	Weight		Tip		Max Load
		kg	lbs	Angle	Radius	
Non-sectioned	835mm/32.874"	8.5	18.74	26°	R0.52	100t/m. 30.48t/ft.
Sectioned					R0.52	
Non-sectioned	415mm/16.339"	4.8	10.58	30°	R0.52	100t/m. 30.48t/ft.
Sectioned					R0.52	
Customizable	Yes					
Material	42CrMo					
Laser Hardening	Yes					
Black Oxidation	Yes					

Config.	Length	Weight		Tip		Max Load
		kg	lbs	Angle	Radius	
Non-sectioned	835mm/32.874"	11.8	26.01	30°	R0.6	100t/m. 30.48t/ft.
Sectioned					R0.6	
Non-sectioned	415mm/16.339"	5.9	13.01	30°	R0.6	100t/m. 30.48t/ft.
Sectioned					R0.6	
Customizable	Yes					
Material	42CrMo					
Laser Hardening	Yes					
Black Oxidation	Yes					

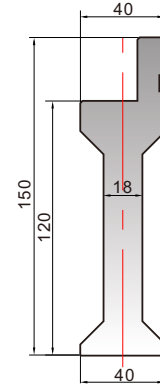
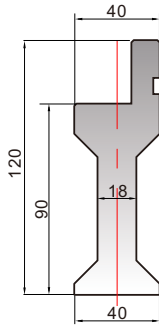

Config.	Length	Weight		Max Load
		kg	lbs	
<b>Non-sectioned</b>	835mm/32.874"	17.3	38.14	100t/m. 30.48t/ft.
<b>Sectioned</b>				
<b>Non-sectioned</b>	415mm/16.339"	8.6	18.96	
<b>Sectioned</b>				
<b>Customizable</b>	Yes			
<b>Material</b>	42CrMo			
<b>Laser Hardening</b>	Yes			
<b>Black Oxidation</b>	Yes			

Config.	Length	Weight		Max Load
		kg	lbs	
<b>Non-sectioned</b>	835mm/32.874"	20.9	22.93	100t/m. 30.48t/ft.
<b>Sectioned</b>				
<b>Non-sectioned</b>	415mm/16.339"	10.4	16.08	
<b>Sectioned</b>				
<b>Customizable</b>	Yes			
<b>Material</b>	42CrMo			
<b>Laser Hardening</b>	Yes			
<b>Black Oxidation</b>	Yes			



W=14

015-14

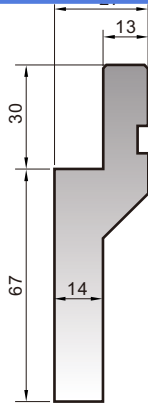

W=16

015-16

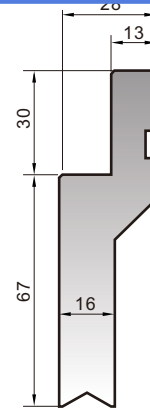

RADIUS PUNCH

H=67

Config.	Length	Weight		Max Load
		kg	lbs	
Non-sectioned	830mm/32.677"	8.5	18.74	100t/m. 30.48t/ft.
Sectioned				
Non-sectioned	410mm/16.142"	4.2	9.26	
Sectioned				
Customizable	Yes			
Material	42CrMo			
Laser Hardening	Yes			
Black Oxidation	Yes			

Config.	Length	Weight		Max Load
		kg	lbs	
Non-sectioned	835mm/32.874"	8.9	19.62	100t/m. 30.48t/ft.
Sectioned				
Non-sectioned	415mm/16.339"	4.4	9.70	
Sectioned				
Customizable	Yes			
Material	42CrMo			
Laser Hardening	Yes			
Black Oxidation	Yes			

W=34

015-34

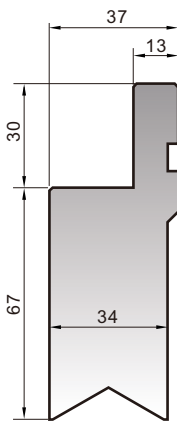

TIP RADIUS

From Ø20 To Ø80

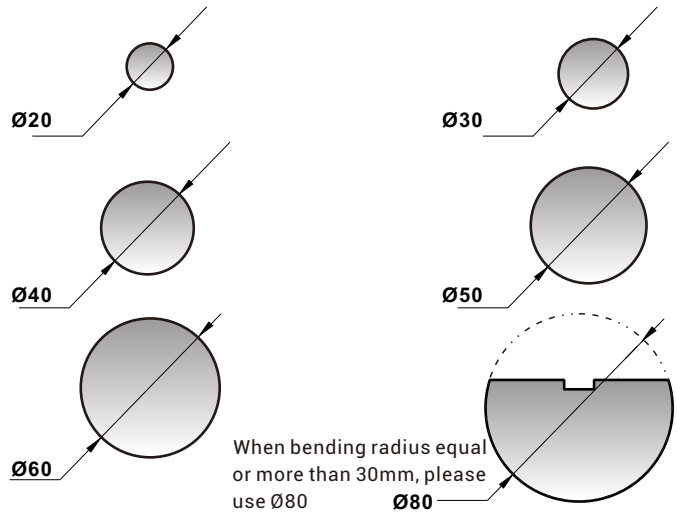

Config.	Length	Weight		Max Load
		kg	lbs	
Non-sectioned	835mm/32.874"	13.6	29.98	100t/m. 30.48t/ft.
Sectioned				
Non-sectioned	415mm/16.339"	6.7	14.77	
Sectioned				
Customizable	Yes			
Material	42CrMo			
Laser Hardening	Yes			
Black Oxidation	Yes			

Config.	Length	Max Load
Non-sectioned	835mm/32.874"	100t/m. 30.48t/ft.
Sectioned		
Non-sectioned	415mm/16.339"	
Sectioned		
Customizable	Yes	
Material	42CrMo	
Laser Hardening	Yes	
Black Oxidation	Yes	

ADJUSTABLE (GUIDE RAIL DIE)

S20

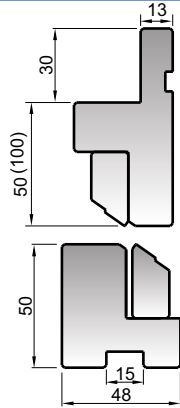

ADJUSTABLE (BOLT-ON DIE)

LS20

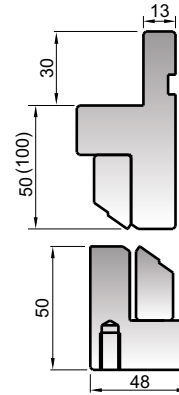

Config.	Length	Max Load
Non-sectioned	835mm/32.874"	60t/m. 18.29t/ft.
Sectioned		
Non-sectioned	415mm/16.339"	
Sectioned		
Customizable	Yes	
Material	42CrMo	
Laser Hardening	Yes	
Black Oxidation	Yes	

Config.	Length	Max Load
Non-sectioned	835mm/32.874"	60t/m. 18.29t/ft.
Sectioned		
Non-sectioned	415mm/16.339"	
Sectioned		
Customizable	Yes	
Material	42CrMo	
Laser Hardening	Yes	
Black Oxidation	Yes	

CUSTOMIZED

SOLID

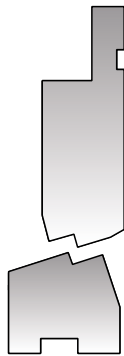

OFFSET BENDING TONNAGE

Note:

Offset Height should be equal or less than 5 times thickness

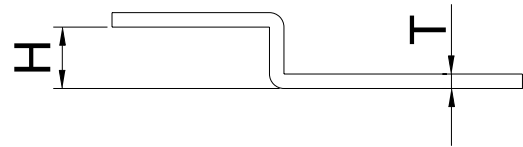

Config.	Length	Max Load
Non-sectioned	835mm/32.874"	60t/m. 18.29t/ft.
Sectioned		
Non-sectioned	415mm/16.339"	
Sectioned		
Customizable	Yes	
Material	42CrMo	
Laser Hardening	Yes	
Black Oxidation	Yes	

OFFSET TONNAGE TABLE		MAX : TON/METER	
SHEET THICKNESS (mm)	H=1T	H=2T	
0.6	8	10	
0.8	13	17	
1.0	18	22	
1.2	25	30	
1.6	43	47	

**Punch:** 100 (left ear), 10, 15, 20, 40, 50, 200, 300, 100(right ear) =835 mm

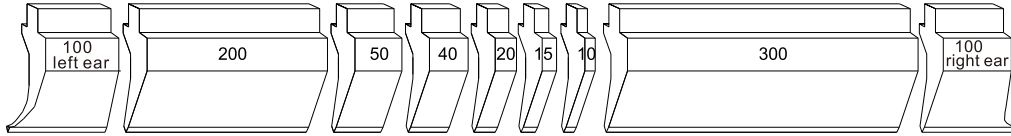

**Die:** 10, 15, 20, 40, 50, 100, 200, 400 =835 mm

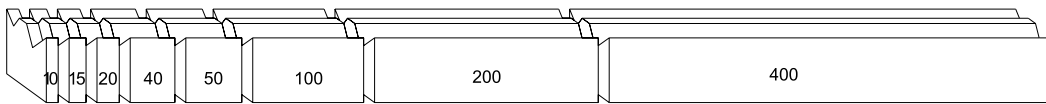

**Available Lengths**

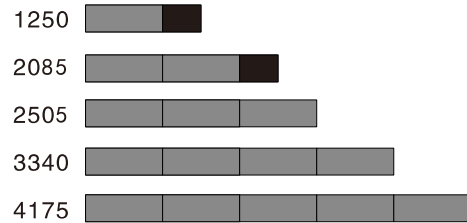
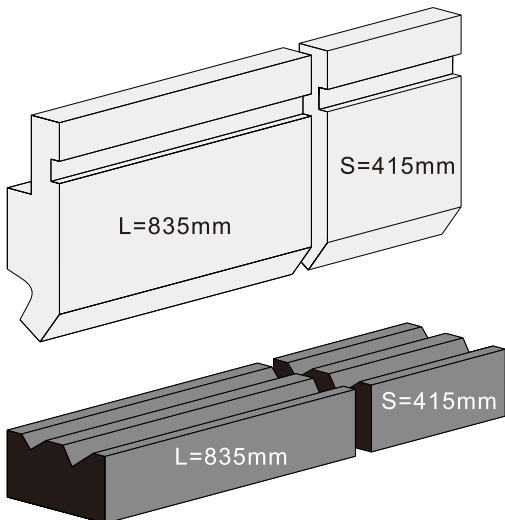

**Standard lengths**

835 mm 415 mm

DIES  
STANDARD LENGTHS & SEGMENTAL

CONCENTRIC 1V DIES	HEAVY 1V DIES	BOLT-ON 1V DIES	SLOT 1V DIES	CONCENTRIC 2V DIES
BOLT-ON 2V DIES	GUIDE RAIL 2V DIES	ROLLER HEMMING DIES	PNEUMATIC ROLLER HEMMING DIES	PNEUMATIC HEMMING DIES
HEMMING DIES 10	HEMMING DIES 115	2V DIE RAIL	DIE HOLDER 330	DIE HOLDER 0815
DIE PAD	DOUBLE-SIDE CLAMP H100	ONE SIDE CLAMP H100	DOUBLE-SIDE CLAMP H200	ONE SIDE CLAMP H200

1V DIE

PRESS BRAKE TOOLING 1V DIE



V32

035

V40

036

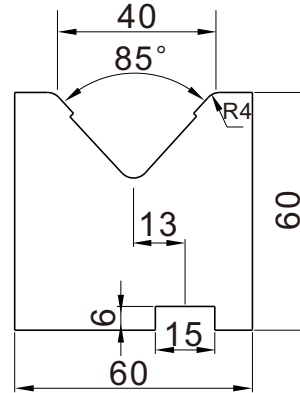
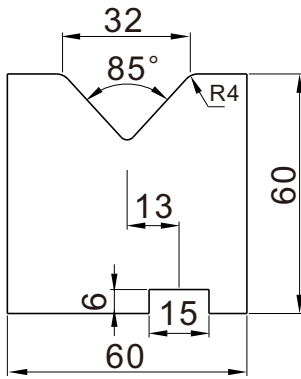

Config.	Length	Weight		V		Max Load
		kg	lbs	Width	Radius	
Non-sectioned	835mm/32.874"	21.1	46.52	V32	R4	100t/m. 30.48t/ft.
Sectioned						
Non-sectioned	415mm/16.339"	10.5	23.15	V32	R4	
Sectioned						
Customizable	Yes					
Material	42CrMo					
Laser Hardening	Yes					
Black Oxidation	Yes					

Config.	Length	Weight		V		Max Load
		kg	lbs	Width	Radius	
Non-sectioned	835mm/32.874"	19.8	43.65	V40	R4	100t/m. 30.48t/ft.
Sectioned						
Non-sectioned	415mm/16.339"	9.9	21.83	V40	R4	
Sectioned						
Customizable	Yes					
Material	42CrMo					
Laser Hardening	Yes					
Black Oxidation	Yes					

V50

037

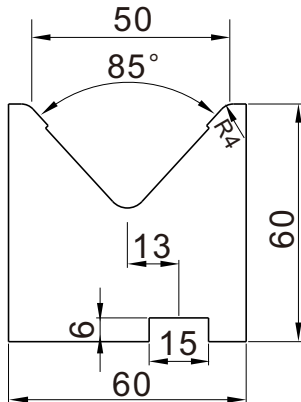

Config.	Length	Weight		V		Max Load
		kg	lbs	Width	Radius	
Non-sectioned	835mm/32.874"	18	39.68	V50	R4	100t/m. 30.48t/ft.
Sectioned						
Non-sectioned	415mm/16.339"	9	19.84	V50	R4	
Sectioned						
Customizable	Yes					
Material	42CrMo					
Laser Hardening	Yes					
Black Oxidation	Yes					

CONCENTRIC TV DIE

86°

V63

038

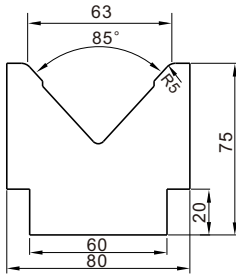

V80

013

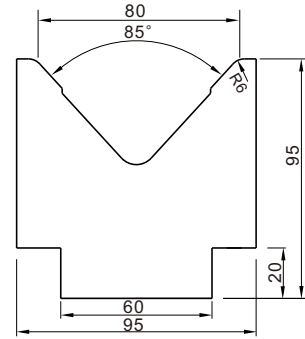

Config.	Length	Weight		V		Max Load
		kg	lbs	Width	Radius	
Non-sectioned	835mm/32.874"	28.8	63.49	V63	R5	100t/m. 30.48t/ft.
Sectioned						
Non-sectioned	415mm/16.339"	14.4	31.75			
Sectioned						
Customizable	Yes					
Material	42CrMo					
Laser Hardening	Yes					
Black Oxidation	Yes					

Config.	Length	Weight		V		Max Load
		kg	lbs	Width	Radius	
Non-sectioned	835mm/32.874"	42.7	94.14	V80	R6	100t/m. 30.48t/ft.
Sectioned						
Non-sectioned	415mm/16.339"	21.2	46.74			
Sectioned						
Customizable	Yes					
Material	42CrMo					
Laser Hardening	Yes					
Black Oxidation	Yes					

HEAVY GAUGE TV DI

85°

V100

018

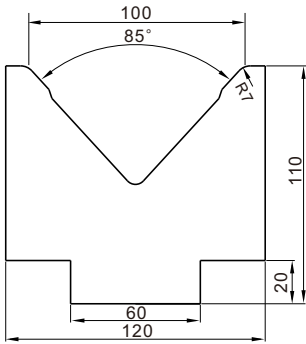

Config.	Length	Weight		V		Max Load
		kg	lbs	Width	Radius	
Non-sectioned	835mm/32.874"	59	130.0	V100	R7	100t/m. 30.48t/ft.
Sectioned						
Non-sectioned	415mm/16.339"	29	63.93			
Sectioned						
Customizable	Yes					
Material	42CrMo					
Laser Hardening	Yes					
Black Oxidation	Yes					

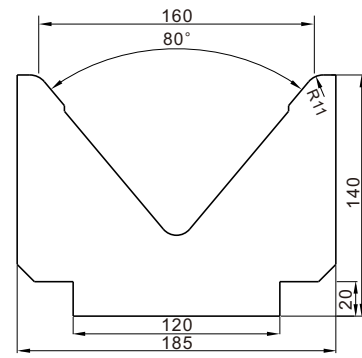
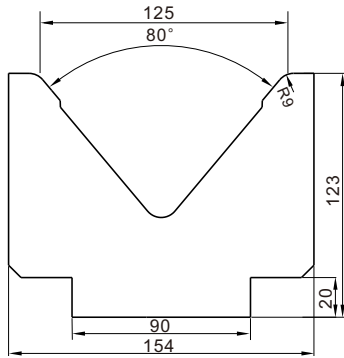

Config.	Length	Weight		V		Max Load
		kg	lbs	Width	Radius	
Non-sectioned	835mm/32.874"	72.8	160.5	V125	R9	100t/m. 30.48t/ft.
Sectioned						
Non-sectioned	415mm/16.339"	36.4	80.25	V125	R9	100t/m. 30.48t/ft.
Sectioned						
Customizable	Yes					
Material	42CrMo					
Laser Hardening	Yes					
Black Oxidation	Yes					

Config.	Length	Weight		V		Max Load
		kg	lbs	Width	Radius	
Non-sectioned	835mm/32.874"	110	242.5	V160	R11	100t/m. 30.48t/ft.
Sectioned						
Non-sectioned	415mm/16.339"	55	121.2	V160	R11	100t/m. 30.48t/ft.
Sectioned						
Customizable	Yes					
Material	42CrMo					
Laser Hardening	Yes					
Black Oxidation	Yes					



V6

320

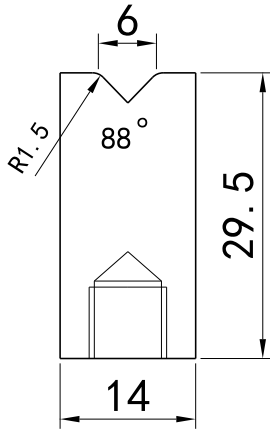

V8

321

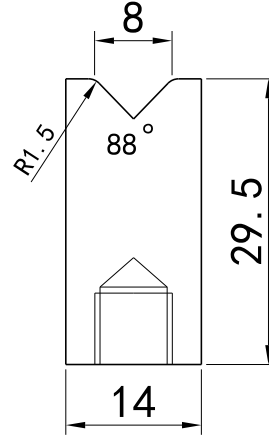

Config.	Length	Weight		V		Max Load
		kg	lbs	Width	Radius	
Non-sectioned	835mm/32.874"	2.8	6.17	V6	R1.5	95t/m. 28.96t/ft.
Sectioned						
Non-sectioned	415mm/16.339"	1.4	3.09	V6	R1.5	95t/m. 28.96t/ft.
Sectioned						
Customizable	Yes					
Material	42CrMo					
Laser Hardening	Yes					
Black Oxidation	Yes					

Config.	Length	Weight		V		Max Load
		kg	lbs	Width	Radius	
Non-sectioned	835mm/32.874"	2.8	6.17	V8	R1.5	95t/m. 28.96t/ft.
Sectioned						
Non-sectioned	415mm/16.339"	1.4	3.09	V8	R1.5	95t/m. 28.96t/ft.
Sectioned						
Customizable	Yes					
Material	42CrMo					
Laser Hardening	Yes					
Black Oxidation	Yes					

V10

322

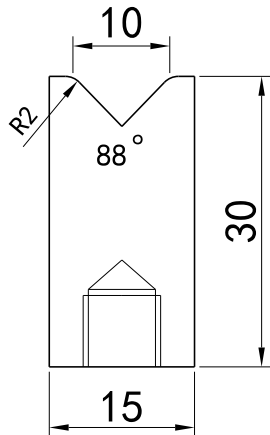

V12

324

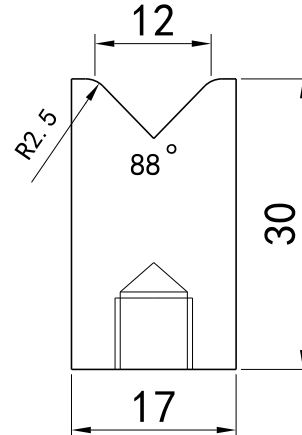

Config.	Length	Weight		V Angle		Max Load
		kg	lbs	Width	Radius	
Non-sectioned	835mm/32.874"	2.8	6.17	V10	R2	95t/m. 28.96t/ft.
Sectioned						
Non-sectioned	415mm/16.339"	1.4	3.09	V10	R2	95t/m. 28.96t/ft.
Sectioned						
Customizable	Yes					
Material	42CrMo					
Laser Hardening	Yes					
Black Oxidation	Yes					

Config.	Length	Weight		V Angle		Max Load
		kg	lbs	Width	Radius	
Non-sectioned	835mm/32.874"	3.1	6.83	V12	R2.5	100t/m. 30.48t/ft.
Sectioned						
Non-sectioned	415mm/16.339"	1.5	3.31	V12	R2.5	100t/m. 30.48t/ft.
Sectioned						
Customizable	Yes					
Material	42CrMo					
Laser Hardening	Yes					
Black Oxidation	Yes					

BOLT-ON TV DIE

88°

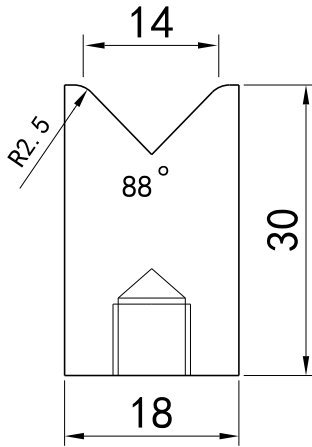

Config.	Length	Weight		V		Max Load
		kg	lbs	Width	Radius	
<b>Non-sectioned</b>	835mm/32.874"	3.2	7.05	V14	R2.5	100t/m. 30.48t/ft.
<b>Sectioned</b>						
<b>Non-sectioned</b>	415mm/16.339"	1.6	3.53	V14	R2.5	
<b>Sectioned</b>						
<b>Customizable</b>	Yes					
<b>Material</b>	42CrMo					
<b>Laser Hardening</b>	Yes					
<b>Black Oxidation</b>	Yes					

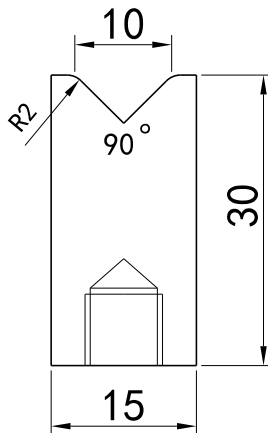

Config.	Length	Weight		V		Max Load
		kg	lbs	Width	Radius	
<b>Non-sectioned</b>	835mm/32.874"	2.8	6.17	V10	R2	95t/m. 28.96t/ft.
<b>Sectioned</b>						
<b>Non-sectioned</b>	415mm/16.339"	1.4	3.09	V10	R2	
<b>Sectioned</b>						
<b>Customizable</b>	Yes					
<b>Material</b>	42CrMo					
<b>Laser Hardening</b>	Yes					
<b>Black Oxidation</b>	Yes					

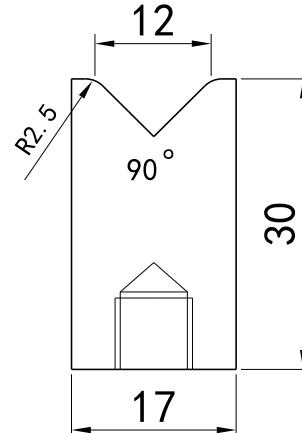

Config.	Length	Weight		V		Max Load
		kg	lbs	Width	Radius	
<b>Non-sectioned</b>	835mm/32.874"	2.8	6.17	V12	R2.5	100t/m. 30.48t/ft.
<b>Sectioned</b>						
<b>Non-sectioned</b>	415mm/16.339"	1.4	3.09	V12	R2.5	
<b>Sectioned</b>						
<b>Customizable</b>	Yes					
<b>Material</b>	42CrMo					
<b>Laser Hardening</b>	Yes					
<b>Black Oxidation</b>	Yes					

V4

084

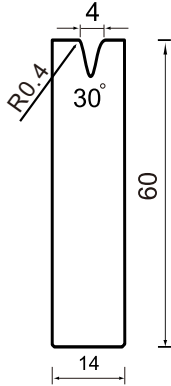

V4

A84

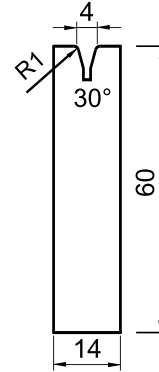

Config.	Length	Weight		V		Max Load
		kg	lbs	Width	Radius	
Non-sectioned	835mm/32.874"	5.4	11.90	V4	R0.4	20t/m. 6.10t/ft.
Sectioned						
Non-sectioned	415mm/16.339"	2.7	5.95	V4	R0.4	20t/m. 6.10t/ft.
Sectioned						
Customizable	Yes					
Material	42CrMo					
Laser Hardening	Yes					
Black Oxidation	Yes					

Config.	Length	Weight		V		Max Load
		kg	lbs	Width	Radius	
Non-sectioned	835mm/32.874"	5.3	11.68	V4	R1	16t/m. 4.88t/ft.
Sectioned						
Non-sectioned	415mm/16.339"	2	4.41	V4	R1	16t/m. 4.88t/ft.
Sectioned						
Customizable	Yes					
Material	42CrMo					
Laser Hardening	Yes					
Black Oxidation	Yes					

SLOT TV DIE

30°

V5

085

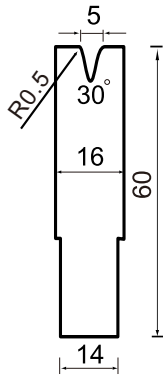

V6

A70

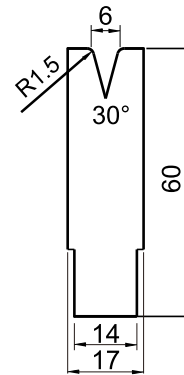

Config.	Length	Weight		V		Max Load
		kg	lbs	Width	Radius	
Non-sectioned	835mm/32.874"	6	13.23	V5	R0.5	20t/m. 6.10t/ft.
Sectioned						
Non-sectioned	415mm/16.339"	3	6.61	V5	R0.5	20t/m. 6.10t/ft.
Sectioned						
Customizable	Yes					
Material	42CrMo					
Laser Hardening	Yes					
Black Oxidation	Yes					

Config.	Length	Weight		V		Max Load
		kg	lbs	Width	Radius	
Non-sectioned	835mm/32.874"	6	13.23	V6	R1.5	18t/m. 5.49t/ft.
Sectioned						
Non-sectioned	415mm/16.339"	3	6.61	V6	R1.5	18t/m. 5.49t/ft.
Sectioned						
Customizable	Yes					
Material	42CrMo					
Laser Hardening	Yes					
Black Oxidation	Yes					

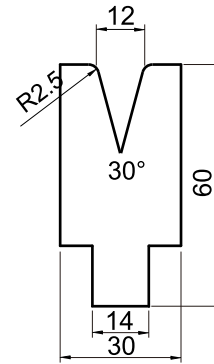
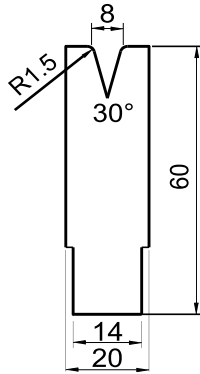

Config.	Length	Weight		V		Max Load
		kg	lbs	Width	Radius	
Non-sectioned	835mm/32.874"	6.8	14.99	V8	R1.5	20t/m. 6.10t/ft.
Sectioned						
Non-sectioned	415mm/16.339"	3.4	7.50	V8	R1.5	20t/m. 6.10t/ft.
Sectioned						
Customizable	Yes					
Material	42CrMo					
Laser Hardening	Yes					
Black Oxidation	Yes					

Config.	Length	Weight		V		Max Load
		kg	lbs	Width	Radius	
Non-sectioned	835mm/32.874"	9.1	20.06	V12	R2.5	30t/m. 9.14t/ft.
Sectioned						
Non-sectioned	415mm/16.339"	4.5	9.92	V12	R2.5	30t/m. 9.14t/ft.
Sectioned						
Customizable	Yes					
Material	42CrMo					
Laser Hardening	Yes					
Black Oxidation	Yes					

V4

A84

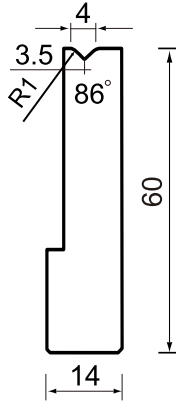

V5

A85

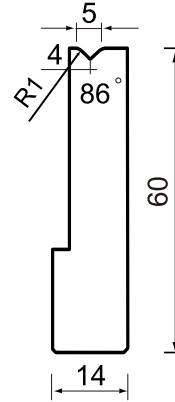

Config.	Length	Weight		V		Max Load
		kg	lbs	Width	Radius	
Non-sectioned	835mm/32.874"	4.5	9.92	V4	R1	40t/m. 12.19t/ft.
Sectioned						
Non-sectioned	415mm/16.339"	2.2	4.85	V4	R1	40t/m. 12.19t/ft.
Sectioned						
Customizable	Yes					
Material	42CrMo					
Laser Hardening	Yes					
Black Oxidation	Yes					

Config.	Length	Weight		V		Max Load
		kg	lbs	Width	Radius	
Non-sectioned	835mm/32.874"	4.3	9.48	V5	R1	50t/m. 15.24t/ft.
Sectioned						
Non-sectioned	415mm/16.339"	2.1	4.63	V5	R1	50t/m. 15.24t/ft.
Sectioned						
Customizable	Yes					
Material	42CrMo					
Laser Hardening	Yes					
Black Oxidation	Yes					

SLOT TV DIE

86°

V6

A70

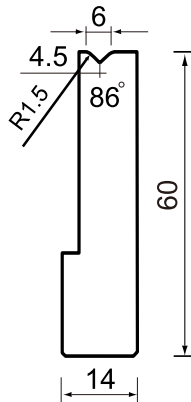

V7

A86

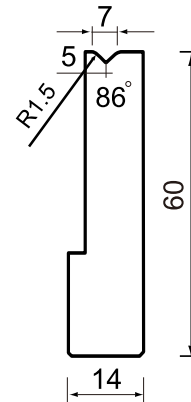

Config.	Length	Weight		V		Max Load
		kg	lbs	Width	Radius	
Non-sectioned	835mm/32.874"	4.7	10.36	V6	R1.5	80t/m. 24.38t/ft.
Sectioned						
Non-sectioned	415mm/16.339"	2.3	5.07	V6	R1.5	80t/m. 24.38t/ft.
Sectioned						
Customizable	Yes					
Material	42CrMo					
Laser Hardening	Yes					
Black Oxidation	Yes					

Config.	Length	Weight		V		Max Load
		kg	lbs	Width	Radius	
Non-sectioned	835mm/32.874"	4.8	10.58	V7	R1.5	85t/m. 25.91t/ft.
Sectioned						
Non-sectioned	415mm/16.339"	2.4	5.29	V7	R1.5	85t/m. 25.91t/ft.
Sectioned						
Customizable	Yes					
Material	42CrMo					
Laser Hardening	Yes					
Black Oxidation	Yes					

V8

A71

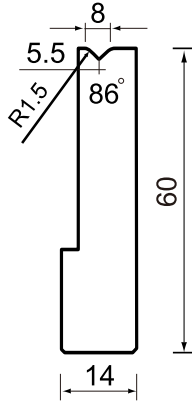

V10

A72

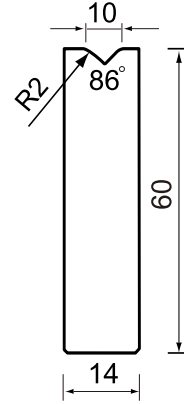

Config.	Length	Weight		V		Max Load
		kg	lbs	Width	Radius	
Non-sectioned	835mm/32.874"	4.9	10.80	V8	R1.5	90t/m. 27.43t/ft.
Sectioned						
Non-sectioned	415mm/16.339"	2.4	5.29	V8	R1.5	
Sectioned						
Customizable	Yes					
Material	42CrMo					
Laser Hardening	Yes					
Black Oxidation	Yes					

Config.	Length	Weight		V		Max Load
		kg	lbs	Width	Radius	
Non-sectioned	835mm/32.874"	5.3	11.68	V10	R2	95t/m. 28.96t/ft.
Sectioned						
Non-sectioned	415mm/16.339"	2.6	5.73	V10	R2	
Sectioned						
Customizable	Yes					
Material	42CrMo					
Laser Hardening	Yes					
Black Oxidation	Yes					

V12

A74

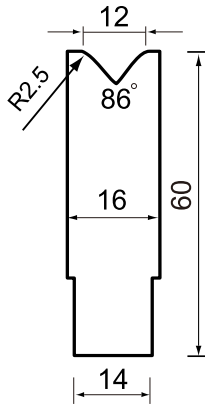

V14

A76

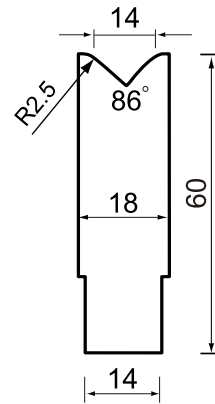

Config.	Length	Weight		V		Max Load
		kg	lbs	Width	Radius	
Non-sectioned	835mm/32.874"	5.8	12.79	V12	R2.5	95t/m. 28.96t/ft.
Sectioned						
Non-sectioned	415mm/16.339"	2.9	6.39	V12	R2.5	
Sectioned						
Customizable	Yes					
Material	42CrMo					
Laser Hardening	Yes					
Black Oxidation	Yes					

Config.	Length	Weight		V Angle		Max Load
		kg	lbs	Width	Radius	
Non-sectioned	835mm/32.874"	6.3	13.89	V14	R2.5	95t/m. 25.90t/ft.
Sectioned						
Non-sectioned	415mm/16.339"	3.15	6.94	V14	R2.5	
Sectioned						
Customizable	Yes					
Material	42CrMo					
Laser Hardening	Yes					
Black Oxidation	Yes					

V16

A77

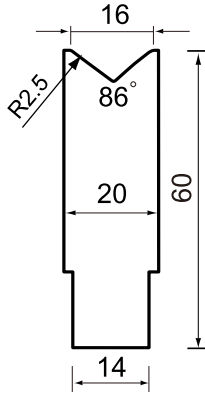

V18

A78

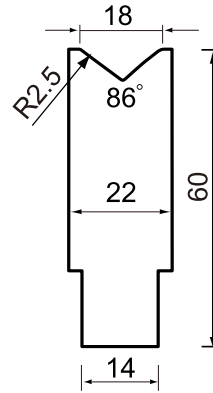

Config.	Length	Weight		V		Max Load
		kg	lbs	Width	Radius	
Non-sectioned	835mm/32.874"	6.8	14.99	V16	R2.5	100t/m. 30.48t/ft.
Sectioned						
Non-sectioned	415mm/16.339"	3.4	7.50	V16	R2.5	
Sectioned						
Customizable	Yes					
Material	42CrMo					
Laser Hardening	Yes					
Black Oxidation	Yes					

Config.	Length	Weight		V		Max Load
		kg	lbs	Width	Radius	
Non-sectioned	835mm/32.874"	7.3	16.09	V18	R2.5	100t/m. 30.48t/ft.
Sectioned						
Non-sectioned	415mm/16.339"	3.6	7.94	V18	R2.5	
Sectioned						
Customizable	Yes					
Material	42CrMo					
Laser Hardening	Yes					
Black Oxidation	Yes					

SLOT TV DIE

86°

V20

A79

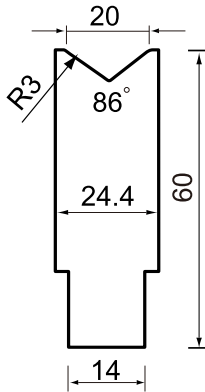

V25

A82

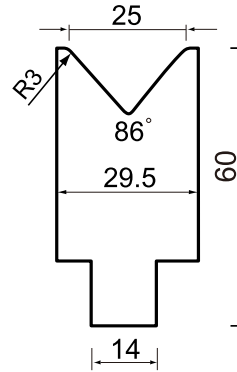

Config.	Length	Weight		V		Max Load
		kg	lbs	Width	Radius	
Non-sectioned	835mm/32.874"	7.8	17.20	V20	R3	100t/m. 30.48t/ft.
Sectioned						
Non-sectioned	415mm/16.339"	3.9	8.60	V20	R3	
Sectioned						
Customizable	Yes					
Material	42CrMo					
Laser Hardening	Yes					
Black Oxidation	Yes					

Config.	Length	Weight		V		Max Load
		kg	lbs	Width	Radius	
Non-sectioned	835mm/32.874"	8.9	19.62	V25	R3	100t/m. 30.48t/ft.
Sectioned						
Non-sectioned	415mm/16.339"	4.4	9.70	V25	R3	
Sectioned						
Customizable	Yes					
Material	42CrMo					
Laser Hardening	Yes					
Black Oxidation	Yes					

V3

083

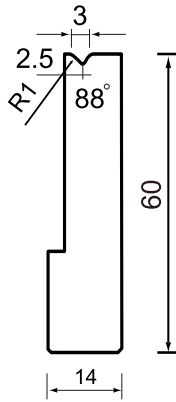

V4

084

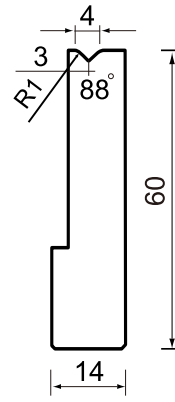

Config.	Length	Weight		V		Max Load
		kg	lbs	Width	Radius	
Non-sectioned	835mm/32.874"	4.2	9.26	V3	R1	40t/m. 12.19t/ft.
Sectioned						
Non-sectioned	415mm/16.339"	2.1	4.63	V3	R1	
Sectioned						
Customizable	Yes					
Material	42CrMo					
Laser Hardening	Yes					
Black Oxidation	Yes					

Config.	Length	Weight		V		Max Load
		kg	lbs	Width	Radius	
Non-sectioned	835mm/32.874"	4.5	9.92	V4	R1	40t/m. 12.19t/ft.
Sectioned						
Non-sectioned	415mm/16.339"	2.2	4.85	V4	R1	
Sectioned						
Customizable	Yes					
Material	42CrMo					
Laser Hardening	Yes					
Black Oxidation	Yes					

V5

085

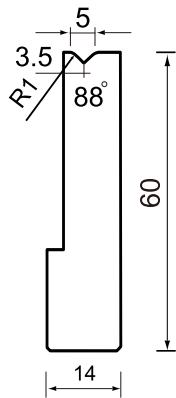

V6

070

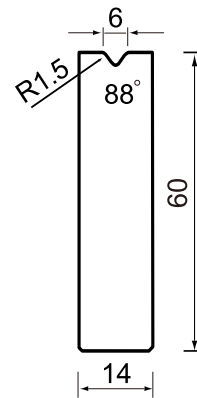

Config.	Length	Weight		V		Max Load
		kg	lbs	Width	Radius	
Non-sectioned	835mm/32.874"	4.5	9.92	V5	R1	50t/m. 15.24t/ft.
Sectioned						
Non-sectioned	415mm/16.339"	2.2	4.85	V5	R1	
Sectioned						
Customizable	Yes					
Material	42CrMo					
Laser Hardening	Yes					
Black Oxidation	Yes					

Config.	Length	Weight		V		Max Load
		kg	lbs	Width	Radius	
Non-sectioned	835mm/32.874"	5.4	11.90	V6	R1.5	95t/m. 25.90t/ft.
Sectioned						
Non-sectioned	415mm/16.339"	2.7	5.95	V6	R1.5	
Sectioned						
Customizable	Yes					
Material	42CrMo					
Laser Hardening	Yes					
Black Oxidation	Yes					



071

072

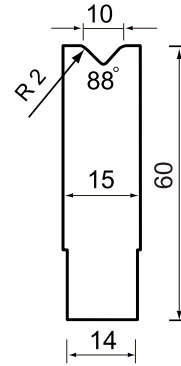
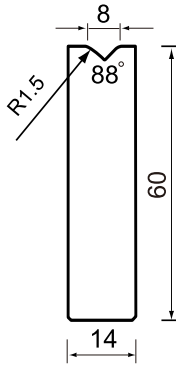

Config.	Length	Weight		V		Max Load
		kg	lbs	Width	Radius	
Non-sectioned	835mm/32.874"	5.4	11.90	V8	R1.5	95t/m. 28.96t/ft.
Sectioned						
Non-sectioned	415mm/16.339"	2.7	5.95	V8	R1.5	95t/m. 28.96t/ft.
Sectioned						
Customizable	Yes					
Material	42CrMo					
Laser Hardening	Yes					
Black Oxidation	Yes					

Config.	Length	Weight		V		Max Load
		kg	lbs	Width	Radius	
Non-sectioned	835mm/32.874"	5.6	12.35	V10	R2	95t/m. 28.96t/ft.
Sectioned						
Non-sectioned	415mm/16.339"	2.8	6.17	V10	R2	95t/m. 28.96t/ft.
Sectioned						
Customizable	Yes					
Material	42CrMo					
Laser Hardening	Yes					
Black Oxidation	Yes					

074

076

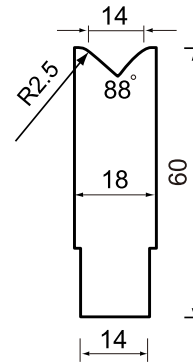
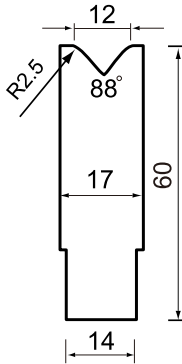

Config.	Length	Weight		V		Max Load
		kg	lbs	Width	Radius	
Non-sectioned	835mm/32.874"	6.1	13.45	V12	R2.5	95t/m. 28.96t/ft.
Sectioned						
Non-sectioned	415mm/16.339"	3	6.61	V12	R2.5	95t/m. 28.96t/ft.
Sectioned						
Customizable	Yes					
Material	42CrMo					
Laser Hardening	Yes					
Black Oxidation	Yes					

Config.	Length	Weight		V		Max Load
		kg	lbs	Width	Radius	
Non-sectioned	835mm/32.874"	6.4	14.11	V14	R2.5	95t/m. 28.96t/ft.
Sectioned						
Non-sectioned	415mm/16.339"	3.2	7.05	V14	R2.5	95t/m. 28.96t/ft.
Sectioned						
Customizable	Yes					
Material	42CrMo					
Laser Hardening	Yes					
Black Oxidation	Yes					

SLOT TV DIE 88°

077

078

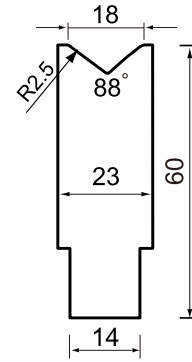
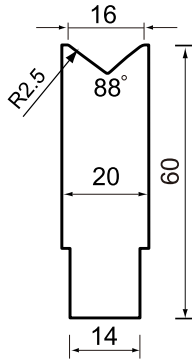

Config.	Length	Weight		V		Max Load
		kg	lbs	Width	Radius	
Non-sectioned	835mm/32.874"	7.1	15.65	V16	R2.5	100t/m. 30.48t/ft.
Sectioned						
Non-sectioned	415mm/16.339"	3.5	7.72	V16	R2.5	
Sectioned						
Customizable	Yes					
Material	42CrMo					
Laser Hardening	Yes					
Black Oxidation	Yes					

Config.	Length	Weight		V		Max Load
		kg	lbs	Width	Radius	
Non-sectioned	835mm/32.874"	7.6	16.76	V18	R2.5	100t/m. 30.48t/ft.
Sectioned						
Non-sectioned	415mm/16.339"	3.8	8.38	V18	R2.5	
Sectioned						
Customizable	Yes					
Material	42CrMo					
Laser Hardening	Yes					
Black Oxidation	Yes					

SLOT TV DIE

88°

079

082

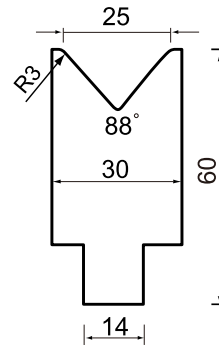
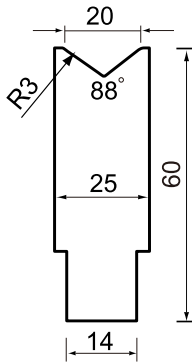

Config.	Length	Weight		V		Max Load
		kg	lbs	Width	Radius	
Non-sectioned	835mm/32.874"	8	17.64	V20	R3	100t/m. 30.48t/ft.
Sectioned						
Non-sectioned	415mm/16.339"	4	8.82	V20	R3	
Sectioned						
Customizable	Yes					
Material	42CrMo					
Laser Hardening	Yes					
Black Oxidation	Yes					

Config.	Length	Weight		V		Max Load
		kg	lbs	Width	Radius	
Non-sectioned	835mm/32.874"	9.2	28.28	V25	R3	100t/m. 30.48t/ft.
Sectioned						
Non-sectioned	415mm/16.339"	4.6	10.14	V25	R3	
Sectioned						
Customizable	Yes					
Material	42CrMo					
Laser Hardening	Yes					
Black Oxidation	Yes					



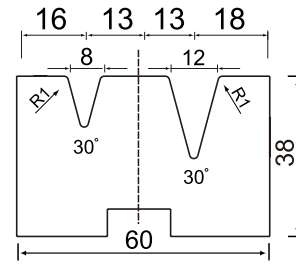
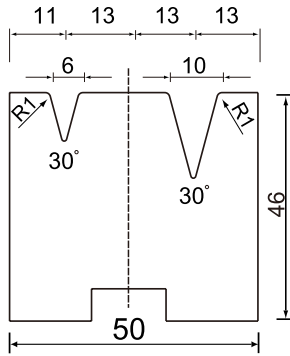

Config.	Length	Weight		V		Max Load
		kg	lbs	Width	Radius	
Non-sectioned	835mm/32.874"	13.6	29.98	V6	R1	26t/m. 7.92t/ft.
Sectioned						
Non-sectioned	415mm/16.339"	6.8	14.99	V10	R1	
Sectioned						
Customizable	Yes					
Material	42CrMo					
Laser Hardening	Yes					
Black Oxidation	Yes					

Config.	Length	Weight		V		Max Load
		kg	lbs	Width	Radius	
Non-sectioned	835mm/32.874"	13	28.66	V8	R1	40t/m. 12.19t/ft.
Sectioned						
Non-sectioned	415mm/16.339"	6.5	14.33	V12	R1	
Sectioned						
Customizable	Yes					
Material	42CrMo					
Laser Hardening	Yes					
Black Oxidation	Yes					

Small Radius

501

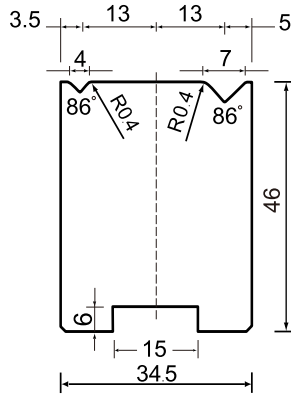

Big Radius

501

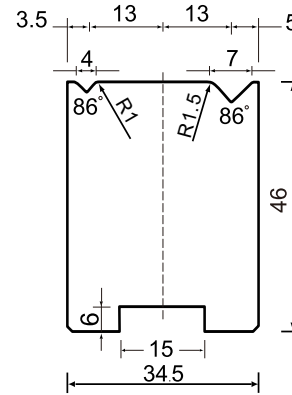

Config.	Length	Weight		V		Max Load
		kg	lbs	Width	Radius	
Non-sectioned	835mm/32.874"	9.6	21.16	V4	R0.4	60t/m.
Sectioned				V7	R0.4	
Non-sectioned	415mm/16.339"	4.8	10.58	V4	R0.4	18.29t/ft.
Sectioned				V7	R0.4	
Customizable	Yes					
Material	42CrMo					
Laser Hardening	Yes					
Black Oxidation	Yes					

Config.	Length	Weight		V		Max Load
		kg	lbs	Width	Radius	
Non-sectioned	835mm/32.874"	9.6	21.16	V4	R1	60t/m.
Sectioned				V7	R1.5	
Non-sectioned	415mm/16.339"	4.8	10.58	V4	R1.5	18.29t/ft.
Sectioned				V7	R1.5	
Customizable	Yes					
Material	42CrMo					
Laser Hardening	Yes					
Black Oxidation	Yes					

CONCENTRIC 2V DIE

86° / H=46

Small Radius

507

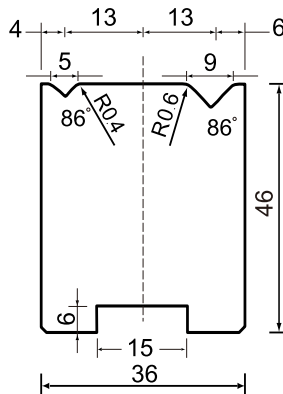

Big Radius

507

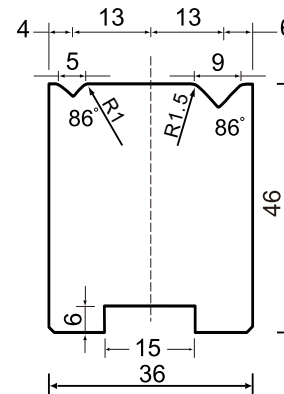

Config.	Length	Weight		V		Max Load
		kg	lbs	Width	Radius	
Non-sectioned	835mm/32.874"	10	22.05	V5	R0.4	70t/m.
Sectioned				V9	R0.6	
Non-sectioned	415mm/16.339"	5	11.02	V5	R0.6	21.34t/ft.
Sectioned				V9	R0.6	
Customizable	Yes					
Material	42CrMo					
Laser Hardening	Yes					
Black Oxidation	Yes					

Config.	Length	Weight		V		Max Load
		kg	lbs	Width	Radius	
Non-sectioned	835mm/32.874"	10	22.05	V5	R1	70t/m.
Sectioned				V9	R1.5	
Non-sectioned	415mm/16.339"	5	11.02	V5	R1.5	21.34t/ft.
Sectioned				V9	R1.5	
Customizable	Yes					
Material	42CrMo					
Laser Hardening	Yes					
Black Oxidation	Yes					

Small Radius

502

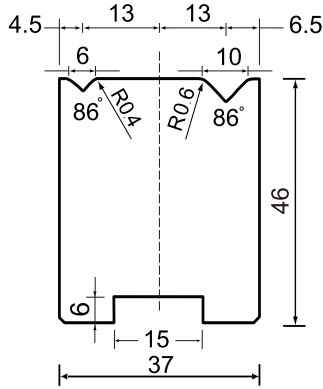

Big Radius

502

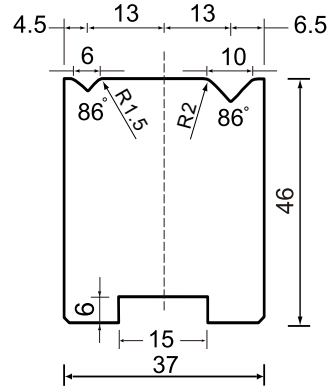

Config.	Length	Weight		V		Max Load
		kg	lbs	Width	Radius	
Non-sectioned	835mm/32.874"	10.8	23.80	V6	R0.4	70t/m. 21.34t/ft.
Sectioned					R0.6	
Non-sectioned	415mm/16.339"	5.4	11.90	V10	R0.6	
Sectioned						
Customizable	Yes					
Material	42CrMo					
Laser Hardening	Yes					
Black Oxidation	Yes					

Config.	Length	Weight		V		Max Load
		kg	lbs	Width	Radius	
Non-sectioned	835mm/32.874"	10.8	23.80	V6	R1	70t/m. 21.34t/ft.
Sectioned					R1.5	
Non-sectioned	415mm/16.339"	5.4	11.90	V10	R1.5	
Sectioned						
Customizable	Yes					
Material	42CrMo					
Laser Hardening	Yes					
Black Oxidation	Yes					

Small Radius

503

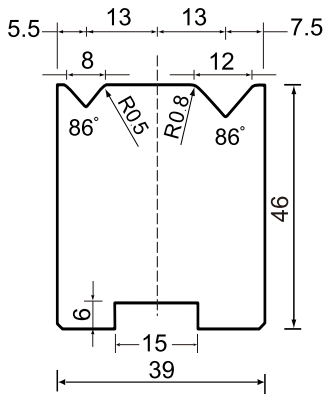

Big Radius

503

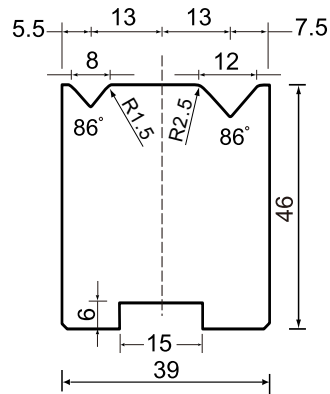

Config.	Length	Weight		V		Max Load
		kg	lbs	Width	Radius	
Non-sectioned	835mm/32.874"	10.8	23.80	V8	R0.5	70t/m. 21.34t/ft.
Sectioned					R0.8	
Non-sectioned	415mm/16.339"	5.4	11.90	V12	R0.8	
Sectioned						
Customizable	Yes					
Material	42CrMo					
Laser Hardening	Yes					
Black Oxidation	Yes					

Config.	Length	Weight		V Angle		Max Load
		kg	lbs	Width	Radius	
Non-sectioned	835mm/32.874"	10.8	23.80	V8	R1.5	70t/m. 21.34t/ft.
Sectioned					R2.5	
Non-sectioned	415mm/16.339"	5.4	11.90	V12	R2.5	
Sectioned						
Customizable	Yes					
Material	42CrMo					
Laser Hardening	Yes					
Black Oxidation	Yes					

Small Radius

504

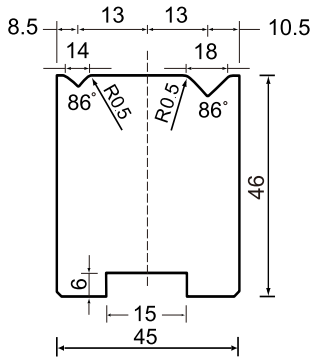

Big Radius

504

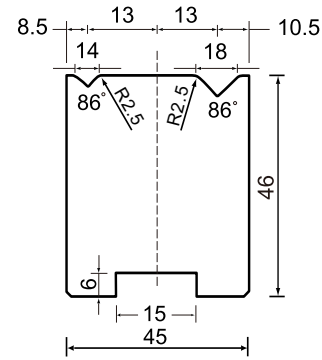

Config.	Length	Weight		V Angle		Max Load
		kg	lbs	Width	Radius	
Non-sectioned	835mm/32.874"	10.8	23.80	V14	R0.5	100t/m. 30.48t/ft.
Sectioned					R0.5	
Non-sectioned	415mm/16.339"	5.4	11.90	V18	R0.5	100t/m. 30.48t/ft.
Sectioned					R0.5	
Customizable	Yes					
Material	42CrMo					
Laser Hardening	Yes					
Black Oxidation	Yes					

Config.	Length	Weight		V Angle		Max Load
		kg	lbs	Width	Radius	
Non-sectioned	835mm/32.874"	10.8	23.80	V14	R2.5	100t/m. 30.48t/ft.
Sectioned					R2.5	
Non-sectioned	415mm/16.339"	5.4	11.90	V18	R2.5	100t/m. 30.48t/ft.
Sectioned					R2.5	
Customizable	Yes					
Material	42CrMo					
Laser Hardening	Yes					
Black Oxidation	Yes					

CONCENTRIC 2V DIE

86° / H=46

Small Radius

505

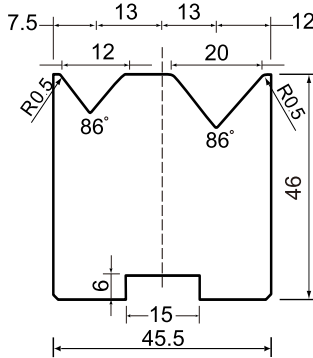

Big Radius

505

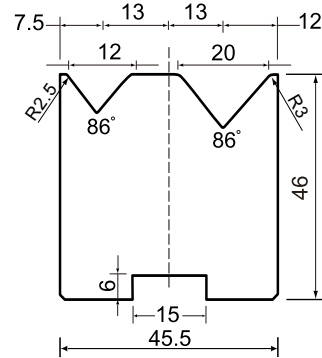

Config.	Length	Weight		V		Max Load
		kg	lbs	Width	Radius	
Non-sectioned	835mm/32.874"	10.8	23.80	V12	R0.5	100t/m. 30.48t/ft.
Sectioned					R0.5	
Non-sectioned	415mm/16.339"	5.4	11.90	V20	R0.5	100t/m. 30.48t/ft.
Sectioned					R0.5	
Customizable	Yes					
Material	42CrMo					
Laser Hardening	Yes					
Black Oxidation	Yes					

Config.	Length	Weight		V		Max Load
		kg	lbs	Width	Radius	
Non-sectioned	835mm/32.874"	10.8	23.80	V12	R2.5	100t/m. 30.48t/ft.
Sectioned					R2.5	
Non-sectioned	415mm/16.339"	5.4	11.90	V20	R3	100t/m. 30.48t/ft.
Sectioned					R3	
Customizable	Yes					
Material	42CrMo					
Laser Hardening	Yes					
Black Oxidation	Yes					

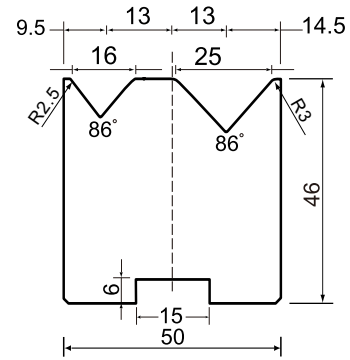
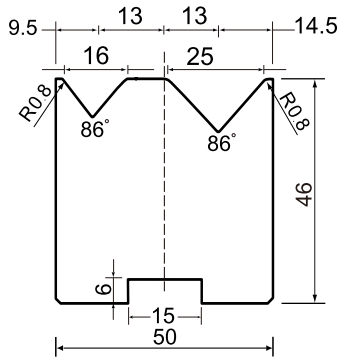

Config.	Length	Weight		V		Max Load
		kg	lbs	Width	Radius	
Non-sectioned	835mm/32.874"	10.8	23.80	V16	R0.4	100t/m.
Sectioned					R0.6	
Non-sectioned	415mm/16.339"	5.4	11.90	V25	R0.6	30.48t/ft.
Sectioned					R0.6	
Customizable	Yes					
Material	42CrMo					
Laser Hardening	Yes					
Black Oxidation	Yes					

Config.	Length	Weight		V		Max Load
		kg	lbs	Width	Radius	
Non-sectioned	835mm/32.874"	10.8	23.80	V16	R2.5	100t/m.
Sectioned					R3	
Non-sectioned	415mm/16.339"	5.4	11.90	V25	R3	30.48t/ft.
Sectioned					R3	
Customizable	Yes					
Material	42CrMo					
Laser Hardening	Yes					
Black Oxidation	Yes					

CONCENTRIC 2V DIE

86° / H=46



Small Radius

501

Big Radius

501

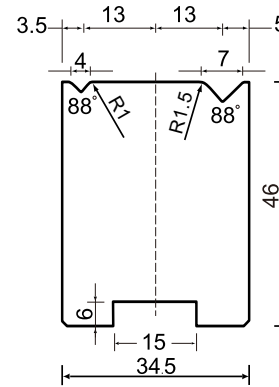
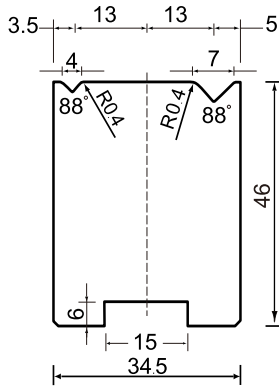

Config.	Length	Weight		V		Max Load
		kg	lbs	Width	Radius	
Non-sectioned	835mm/32.874"	10.8	23.80	V4	R0.4	60t/m. 18.29t/ft.
Sectioned				V7	R0.4	
Non-sectioned	415mm/16.339"	5.4	11.90			
Sectioned						
Customizable	Yes					
Material	42CrMo					
Laser Hardening	Yes					
Black Oxidation	Yes					

Config.	Length	Weight		V		Max Load
		kg	lbs	Width	Radius	
Non-sectioned	835mm/32.874"	10.8	23.80	V4	R1	60t/m. 18.29t/ft.
Sectioned				V7	R1.5	
Non-sectioned	415mm/16.339"	5.4	11.90			
Sectioned						
Customizable	Yes					
Material	42CrMo					
Laser Hardening	Yes					
Black Oxidation	Yes					

CONCENTRIC 2V DIE

86° / H=46

Small Radius

507

Big Radius

507

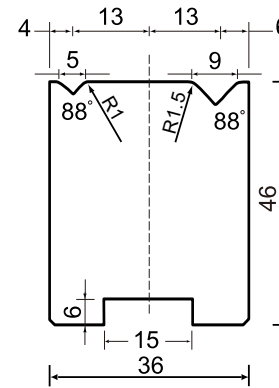
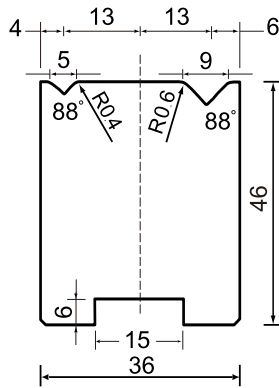

Config.	Length	Weight		V Angle		Max Load
		kg	lbs	Width	Radius	
Non-sectioned	835mm/32.874"	10.8	23.80	V5	R0.4	70t/m. 21.34t/ft.
Sectioned				V9	R0.6	
Non-sectioned	415mm/16.339"	5.4	11.90			
Sectioned						
Customizable	Yes					
Material	42CrMo					
Laser Hardening	Yes					
Black Oxidation	Yes					

Config.	Length	Weight		V Angle		Max Load
		kg	lbs	Width	Radius	
Non-sectioned	835mm/32.874"	10.8	23.80	V5	R1	70t/m. 21.34t/ft.
Sectioned				V9	R1.5	
Non-sectioned	415mm/16.339"	5.4	11.90			
Sectioned						
Customizable	Yes					
Material	42CrMo					
Laser Hardening	Yes					
Black Oxidation	Yes					

Small Radius

502

Big Radius

502

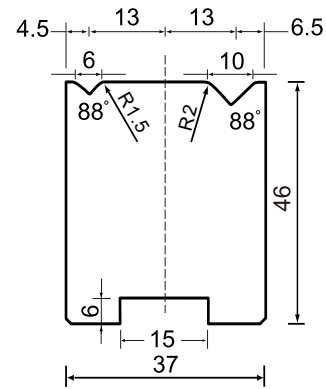
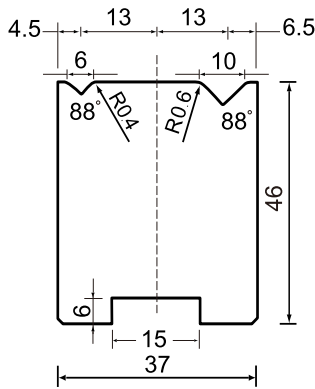

Config.	Length	Weight		V		Max Load
		kg	lbs	Width	Radius	
Non-sectioned	835mm/32.874"	10.8	23.80	V6	R0.4	70t/m.
Sectioned					R0.6	
Non-sectioned	415mm/16.339"	5.4	11.90	V10	R0.6	21.34t/ft.
Sectioned						
Customizable	Yes					
Material	42CrMo					
Laser Hardening	Yes					
Black Oxidation	Yes					

Config.	Length	Weight		V		Max Load
		kg	lbs	Width	Radius	
Non-sectioned	835mm/32.874"	10.8	23.80	V6	R1.5	70t/m.
Sectioned					R2	
Non-sectioned	415mm/16.339"	5.4	11.90	V10	R2	21.34t/ft.
Sectioned						
Customizable	Yes					
Material	42CrMo					
Laser Hardening	Yes					
Black Oxidation	Yes					

Small Radius

503

Big Radius

503

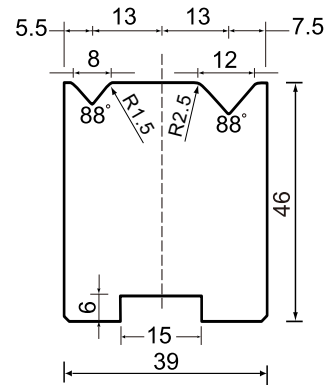
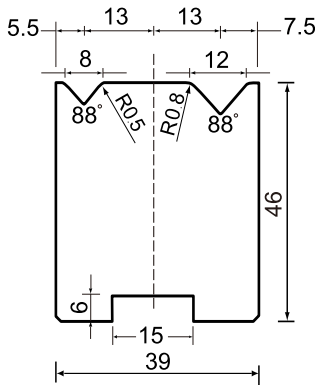

Config.	Length	Weight		V		Max Load
		kg	lbs	Width	Radius	
Non-sectioned	835mm/32.874"	10.8	23.80	V8	R0.5	70t/m.
Sectioned					R0.8	
Non-sectioned	415mm/16.339"	5.4	11.90	V12	R0.8	21.34t/ft.
Sectioned						
Customizable	Yes					
Material	42CrMo					
Laser Hardening	Yes					
Black Oxidation	Yes					

Config.	Length	Weight		V		Max Load
		kg	lbs	Width	Radius	
Non-sectioned	835mm/32.874"	10.8	23.80	V8	R1.5	70t/m.
Sectioned					R2.5	
Non-sectioned	415mm/16.339"	5.4	11.90	V12	R2.5	21.34t/ft.
Sectioned						
Customizable	Yes					
Material	42CrMo					
Laser Hardening	Yes					
Black Oxidation	Yes					

Small Radius

504

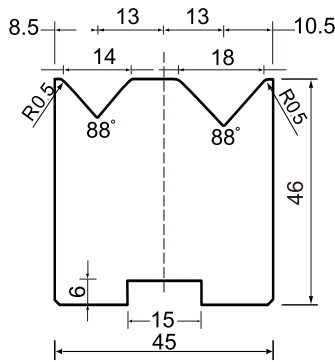

Big Radius

504

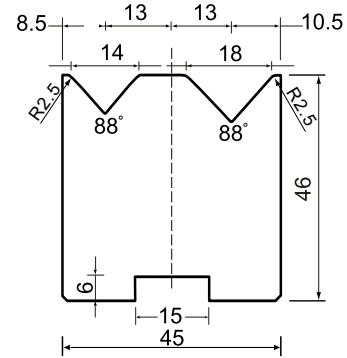

Config.	Length	Weight		V		Max Load
		kg	lbs	Width	Radius	
Non-sectioned	835mm/32.874"	10.8	23.80	V14	R0.5	100t/m. 30.48t/ft.
Sectioned				V18	R0.5	
Non-sectioned	415mm/16.339"	5.4	11.90	V14	R0.5	100t/m. 30.48t/ft.
Sectioned				V18	R0.5	
Customizable	Yes					
Material	42CrMo					
Laser Hardening	Yes					
Black Oxidation	Yes					

Config.	Length	Weight		V		Max Load
		kg	lbs	Width	Radius	
Non-sectioned	835mm/32.874"	10.8	23.80	V14	R2.5	100t/m. 30.48t/ft.
Sectioned				V18	R2.5	
Non-sectioned	415mm/16.339"	5.4	11.90	V14	R2.5	100t/m. 30.48t/ft.
Sectioned				V18	R2.5	
Customizable	Yes					
Material	42CrMo					
Laser Hardening	Yes					
Black Oxidation	Yes					

CONCENTRIC 2V DIE

86° / H=46

Small Radius

505

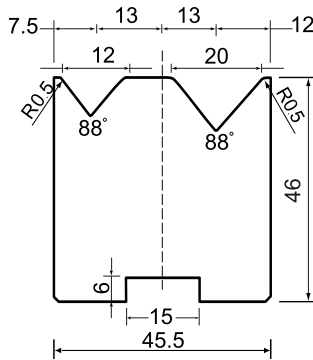

Big Radius

505

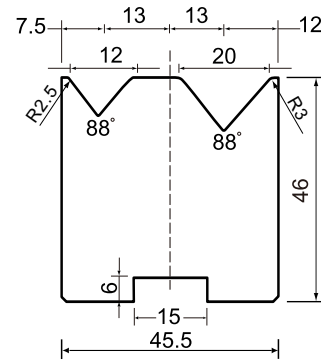

Config.	Length	Weight		V Angle		Max Load
		kg	lbs	Width	Radius	
Non-sectioned	835mm/32.874"	10.8	23.80	V12	R0.5	100t/m. 30.48t/ft.
Sectioned				V20	R0.5	
Non-sectioned	415mm/16.339"	5.4	11.90	V12	R0.5	100t/m. 30.48t/ft.
Sectioned				V20	R0.5	
Customizable	Yes					
Material	42CrMo					
Laser Hardening	Yes					
Black Oxidation	Yes					

Config.	Length	Weight		V Angle		Max Load
		kg	lbs	Width	Radius	
Non-sectioned	835mm/32.874"	10.8	23.80	V12	R2.5	100t/m. 30.48t/ft.
Sectioned				V20	R3	
Non-sectioned	415mm/16.339"	5.4	11.90	V12	R3	100t/m. 30.48t/ft.
Sectioned				V20	R3	
Customizable	Yes					
Material	42CrMo					
Laser Hardening	Yes					
Black Oxidation	Yes					

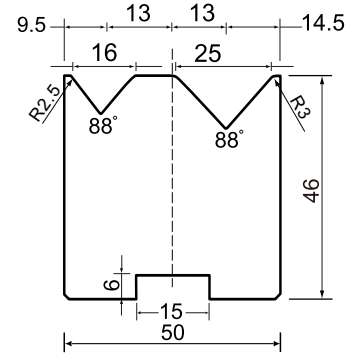
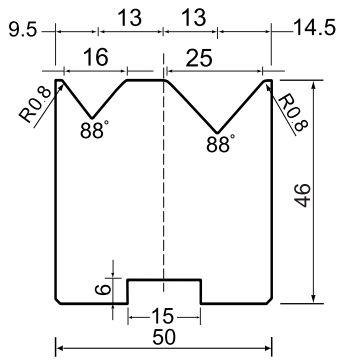

Config.	Length	Weight		V		Max Load
		kg	lbs	Width	Radius	
Non-sectioned	835mm/32.874"	10.8	23.80	V6	R0.4	100t/m.
Sectioned					R0.6	
Non-sectioned	415mm/16.339"	5.4	11.90	V10	R0.6	30.48t/ft.
Sectioned					R0.6	
Customizable	Yes					
Material	42CrMo					
Laser Hardening	Yes					
Black Oxidation	Yes					

Config.	Length	Weight		V		Max Load
		kg	lbs	Width	Radius	
Non-sectioned	835mm/32.874"	10.8	23.80	V6	R1.5	100t/m.
Sectioned					R2	
Non-sectioned	415mm/16.339"	5.4	11.90	V10	R2	30.48t/ft.
Sectioned					R2	
Customizable	Yes					
Material	42CrMo					
Laser Hardening	Yes					
Black Oxidation	Yes					

501

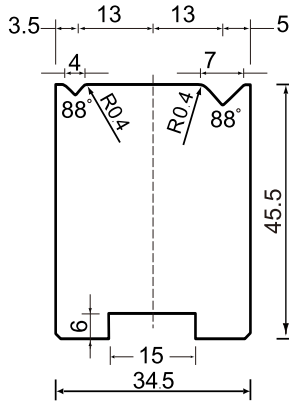

Config.	Length	Weight		V		Max Load
		kg	lbs	Width	Radius	
Non-sectioned	835mm/32.874"	10.8	23.80	V4	R0.4	60t/m.
Sectioned				V7	R0.4	
Non-sectioned	415mm/16.339"	5.4	11.90			18.29t/ft.
Sectioned						
Customizable	Yes					
Material	42CrMo					
Laser Hardening	Yes					
Black Oxidation	Yes					

507

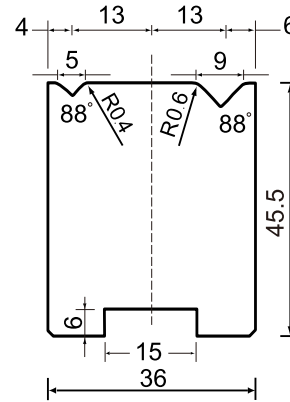

Config.	Length	Weight		V		Max Load
		kg	lbs	Width	Radius	
Non-sectioned	835mm/32.874"	10.8	23.80	V5	R0.4	70t/m.
Sectioned				V9	R0.6	
Non-sectioned	415mm/16.339"	5.4	11.90			21.34t/ft.
Sectioned						
Customizable	Yes					
Material	42CrMo					
Laser Hardening	Yes					
Black Oxidation	Yes					

502

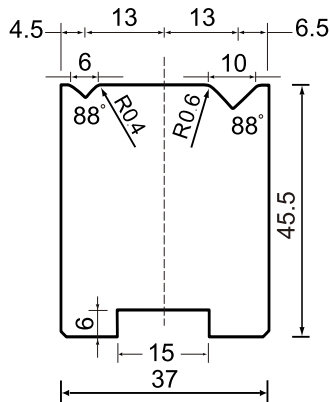

Config.	Length	Weight		V		Max Load
		kg	lbs	Width	Radius	
Non-sectioned	835mm/32.874"	10.8	23.80	V6	R0.4	70t/m.
Sectioned				V10	R0.6	
Non-sectioned	415mm/16.339"	5.4	11.90			21.34t/ft.
Sectioned						
Customizable	Yes					
Material	42CrMo					
Laser Hardening	Yes					
Black Oxidation	Yes					

503

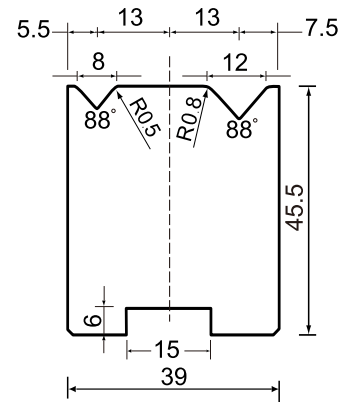

Config.	Length	Weight		V		Max Load
		kg	lbs	Width	Radius	
Non-sectioned	835mm/32.874"	10.8	23.80	V8	R0.5	70t/m.
Sectioned				V12	R0.8	
Non-sectioned	415mm/16.339"	5.4	11.90			21.34t/ft.
Sectioned						
Customizable	Yes					
Material	42CrMo					
Laser Hardening	Yes					
Black Oxidation	Yes					

CONCENTRIC 2V DIE

88° / H=45.5

301

307

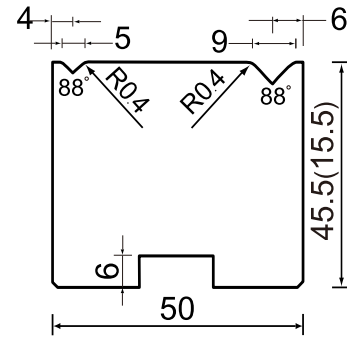
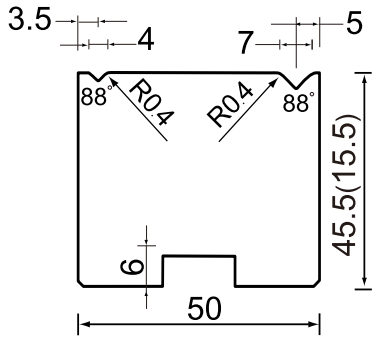

Config.	Length	Weight		V		Max Load
		kg	lbs	Width	Radius	
Non-sectioned	835mm/32.874"	12.6	27.78	V6	R0.4	70t/m. 21.34t/ft.
Sectioned					R0.6	
Non-sectioned	415mm/16.339"	6.8	14.99	V10	R0.6	70t/m. 21.34t/ft.
Sectioned					R1.5	
Customizable	Yes					
Material	42CrMo					
Laser Hardening	Yes					
Black Oxidation	Yes					

Config.	Length	Weight		V		Max Load
		kg	lbs	Width	Radius	
Non-sectioned	835mm/32.874"	14.3	31.53	V6	R1	70t/m. 21.34t/ft.
Sectioned					R1.5	
Non-sectioned	415mm/16.339"	7.2	15.87	V10	R1.5	70t/m. 21.34t/ft.
Sectioned					R1.5	
Customizable	Yes					
Material	42CrMo					
Laser Hardening	Yes					
Black Oxidation	Yes					

GUIDE RAIL 2V DIE

88°

302

303

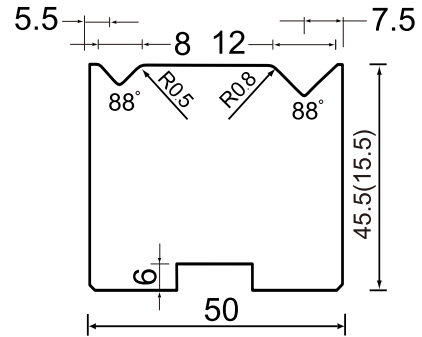
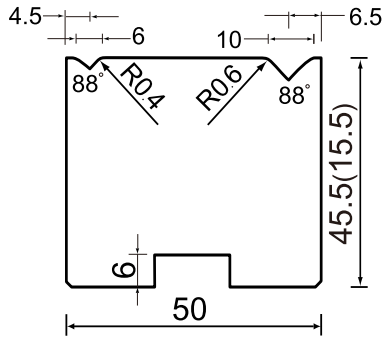

Config.	Length	Weight		V		Max Load
		kg	lbs	Width	Radius	
Non-sectioned	835mm/32.874"	10.8	23.80	V8	R0.5	70t/m. 21.34t/ft.
Sectioned					R0.8	
Non-sectioned	415mm/16.339"	5.4	11.90	V12	R0.8	70t/m. 21.34t/ft.
Sectioned					R1.5	
Customizable	Yes					
Material	42CrMo					
Laser Hardening	Yes					
Black Oxidation	Yes					

Config.	Length	Weight		V Angle		Max Load
		kg	lbs	Width	Radius	
Non-sectioned	835mm/32.874"	10.8	23.80	V8	R1.5	70t/m. 21.34t/ft.
Sectioned					R2.5	
Non-sectioned	415mm/16.339"	5.4	11.90	V12	R1.5	70t/m. 21.34t/ft.
Sectioned					R2.5	
Customizable	Yes					
Material	42CrMo					
Laser Hardening	Yes					
Black Oxidation	Yes					

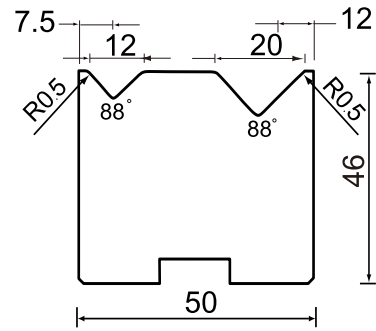
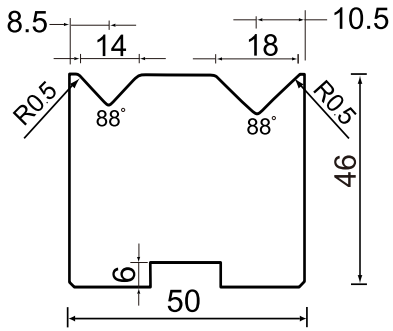

Config.	Length	Weight		V		Max Load
		kg	lbs	Width	Radius	
Non-sectioned	835mm/32.874"	14.5	31.97	V4	R0.4	60t/m. 18.29t/ft.
Sectioned				V7	R0.4	
Non-sectioned	415mm/16.339"	8.1	17.86			
Sectioned						
Customizable	Yes					
Material	42CrMo					
Laser Hardening	Yes					
Black Oxidation	Yes					

Config.	Length	Weight		V		Max Load
		kg	lbs	Width	Radius	
Non-sectioned	835mm/32.874"	13.6	29.98	V5	R0.4	70t/m. 21.34t/ft.
Sectioned				V9	R0.6	
Non-sectioned	415mm/16.339"	7.5	16.53			
Sectioned						
Customizable	Yes					
Material	42CrMo					
Laser Hardening	Yes					
Black Oxidation	Yes					

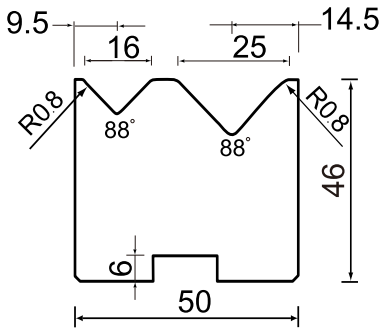

Config.	Length	Weight		V		Max Load
		kg	lbs	Width	Radius	
Non-sectioned	835mm/32.874"	15.6	34.39	V6	R0.4	70t/m. 21.34t/ft.
Sectioned				V10	R0.6	
Non-sectioned	415mm/16.339"	8.7	19.18			
Sectioned						
Customizable	Yes					
Material	42CrMo					
Laser Hardening	Yes					
Black Oxidation	Yes					

GUIDE RAIL 2V DIE

86° / H=46

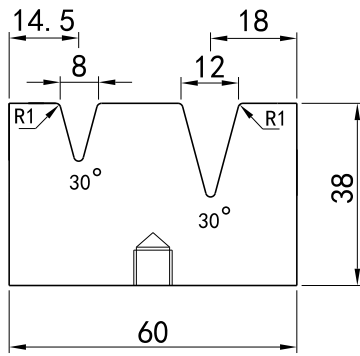

Config.	Length	Weight		V		Max Load
		kg	lbs	Width	Radius	
<b>Non-sectioned</b>	835mm/32.874"	14	30.86	V6	R0.4	70t/m. 21.34t/ft.
<b>Sectioned</b>				V10	R0.6	
<b>Non-sectioned</b>	415mm/16.339"	7	15.43	V6	R0.4	
<b>Sectioned</b>				V10	R0.6	
<b>Customizable</b>	Yes					
<b>Material</b>	42CrMo					
<b>Laser Hardening</b>	Yes					
<b>Black Oxidation</b>	Yes					



121

122

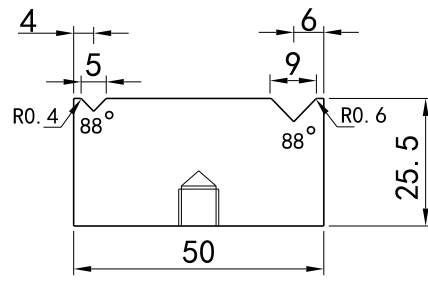
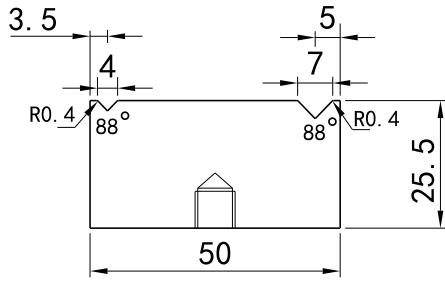

Config.	Length	Weight		V		Max Load
		kg	lbs	Width	Radius	
Non-sectioned	835mm/32.874"	8.3	18.30	V4	R0.4	60t/m. 18.29t/ft.
Sectioned				V7	R0.4	
Non-sectioned	415mm/16.339"	4.1	9.04			
Sectioned						
Customizable	Yes					
Material	42CrMo					
Laser Hardening	Yes					
Black Oxidation	Yes					

Config.	Length	Weight		V		Max Load
		kg	lbs	Width	Radius	
Non-sectioned	835mm/32.874"	8.3	18.30	V5	R0.4	70t/m. 21.34t/ft.
Sectioned				V9	R0.6	
Non-sectioned	415mm/16.339"	4.1	9.04			
Sectioned						
Customizable	Yes					
Material	42CrMo					
Laser Hardening	Yes					
Black Oxidation	Yes					

123

311

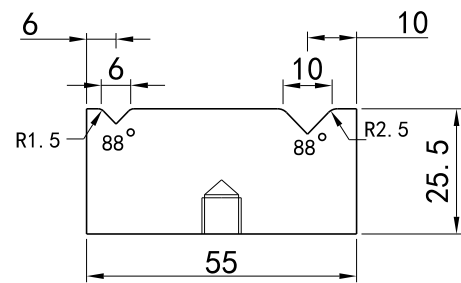
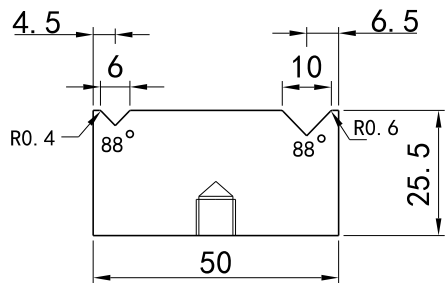

Config.	Length	Weight		V		Max Load
		kg	lbs	Width	Radius	
Non-sectioned	835mm/32.874"	8.3	18.30	V6	R0.4	70t/m. 21.34t/ft.
Sectioned				V10	R0.6	
Non-sectioned	415mm/16.339"	4.1	9.04			
Sectioned						
Customizable	Yes					
Material	42CrMo					
Laser Hardening	Yes					
Black Oxidation	Yes					

Config.	Length	Weight		V		Max Load
		kg	lbs	Width	Radius	
Non-sectioned	835mm/32.874"	9	19.84	V8	R0.5	70t/m. 21.34t/ft.
Sectioned				V12	R0.8	
Non-sectioned	415mm/16.339"	4.5	9.92			
Sectioned						
Customizable	Yes					
Material	42CrMo					
Laser Hardening	Yes					
Black Oxidation	Yes					

BOLT-ON 2V DIE

88°

124

126

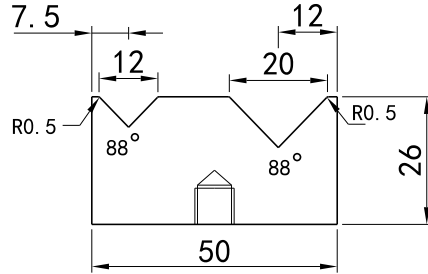
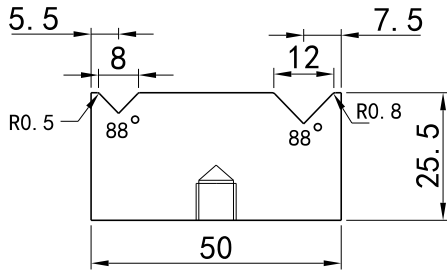

Config.	Length	Weight		V		Max Load
		kg	lbs	Width	Radius	
Non-sectioned	835mm/32.874"	8.3	18.30	V6	R0.4	70t/m. 21.34t/ft.
Sectioned						
Non-sectioned	415mm/16.339"	4.1	9.04	V10	R0.6	
Sectioned						
Customizable	Yes					
Material	42CrMo					
Laser Hardening	Yes					
Black Oxidation	Yes					

Config.	Length	Weight		V		Max Load
		kg	lbs	Width	Radius	
Non-sectioned	835mm/32.874"	8	17.64	V6	R1	70t/m. 21.34t/ft.
Sectioned						
Non-sectioned	415mm/16.339"	4	8.82	V10	R1.5	
Sectioned						
Customizable	Yes					
Material	42CrMo					
Laser Hardening	Yes					
Black Oxidation	Yes					

BOLT-ON 2V DIE

88°

314

125

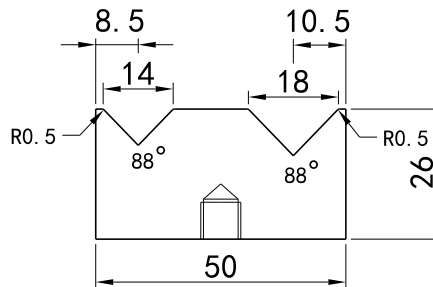
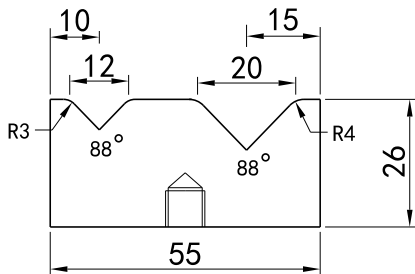

Config.	Length	Weight		V		Max Load
		kg	lbs	Width	Radius	
Non-sectioned	835mm/32.874"	7	15.43	V8	R0.5	70t/m. 21.34t/ft.
Sectioned						
Non-sectioned	415mm/16.339"	3.5	7.72	V12	R0.8	
Sectioned						
Customizable	Yes					
Material	42CrMo					
Laser Hardening	Yes					
Black Oxidation	Yes					

Config.	Length	Weight		V Angle		Max Load
		kg	lbs	Width	Radius	
Non-sectioned	835mm/32.874"	8	17.64	V8	R1.5	70t/m. 21.34t/ft.
Sectioned						
Non-sectioned	415mm/16.339"	4	8.82	V12	R2.5	
Sectioned						
Customizable	Yes					
Material	42CrMo					
Laser Hardening	Yes					
Black Oxidation	Yes					

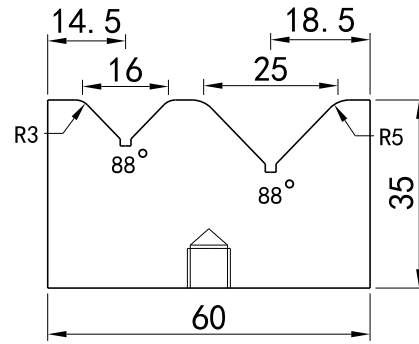
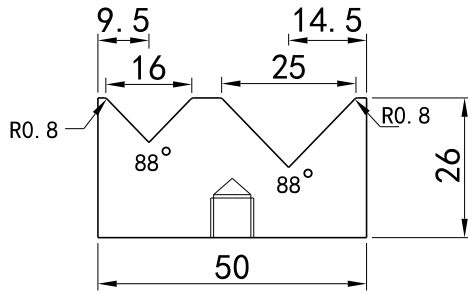

Config.	Length	Weight		V		Max Load
		kg	lbs	Width	Radius	
Non-sectioned	835mm/32.874"	7	15.43	V4	R0.4	60t/m.
Sectioned				V7	R0.4	
Non-sectioned	415mm/16.339"	3.5	7.72	V4	R0.4	18.29t/ft.
Sectioned				V7	R0.4	
Customizable	Yes					
Material	42CrMo					
Laser Hardening	Yes					
Black Oxidation	Yes					

Config.	Length	Weight		V		Max Load
		kg	lbs	Width	Radius	
Non-sectioned	835mm/32.874"	12.4	27.34	V5	R0.4	70t/m.
Sectioned				V9	R0.6	
Non-sectioned	415mm/16.339"	6.2	13.67	V5	R0.6	21.34t/ft.
Sectioned				V9	R0.6	
Customizable	Yes					
Material	42CrMo					
Laser Hardening	Yes					
Black Oxidation	Yes					

BOLT-ON 2V DIE

88°



**ROLLER HEMMING DIE**

**10**

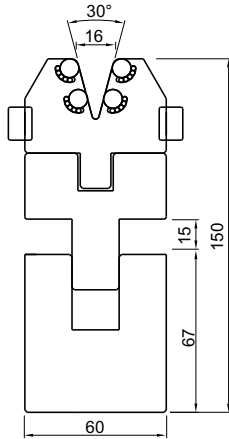

Config.	Length	Weight		V Width	Max Load
		kg	lbs		
Non-sectioned	800mm/31.496"			V6	80t/m(24.38t/ft)
Sectioned				V10	
Non-sectioned	400mm/15.748"			V12	100t/m(30.48t/ft)
Sectioned				V16	
Customizable	Yes				
Material	42CrMo				
Laser Hardening	Yes				
Black Oxidation	Yes				

**PNEUMATIC ROLLER HEMMING DIE**

**10**

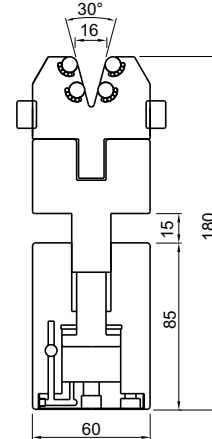

Config.	Length	Weight		V Width	Max Load
		kg	lbs		
Non-sectioned	800mm/31.496"			V10	100t/m(30.48t/ft)
Sectioned				V16	
Non-sectioned	400mm/15.748"			V10	100t/m(30.48t/ft)
Sectioned				V16	
Customizable	Yes				
Material	42CrMo				
Laser Hardening	Yes				
Black Oxidation	Yes				

**HEMMING DIE**

**30°**

**PNEUMATIC HEMMING DIES**

**10**

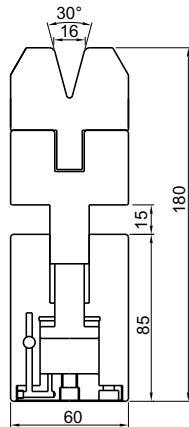

Config.	Length	Weight		V Width	Max Load
		kg	lbs		
Non-sectioned	835mm/32.874"			V10	100t/m(30.48t/ft)
Sectioned				V16	
Non-sectioned	415mm/16.339"			V10	100t/m(30.48t/ft)
Sectioned				V16	
Customizable	Yes				
Material	42CrMo				
Laser Hardening	Yes				
Black Oxidation	Yes				

**HEMMING DIES**

**10**

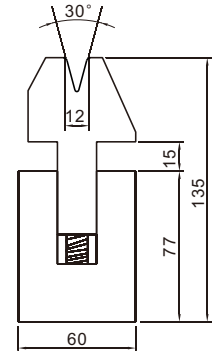

Config.	Length	Weight		V Width	Max Load
		kg	lbs		
Non-sectioned	835mm/32.874"			V6	80t/m (24.38t/ft)
Sectioned				V8	
Non-sectioned	415mm/16.339"			V10	100t/m (30.48t/ft)
Sectioned				V12	
Sectioned				V16	
Customizable	Yes				
Material	42CrMo				
Laser Hardening	Yes				
Black Oxidation	Yes				

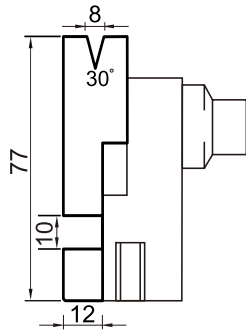

Config.	Length	Weight		V	Max Load
		kg	lbs	Width	
<b>Non-sectioned</b>	835mm/32.874"			V6	80t/m(24.38t/ft)
<b>Sectioned</b>					
<b>Non-sectioned</b>	415mm/16.339"			V8	
<b>Sectioned</b>					
<b>Customizable</b>	Yes				
<b>Material</b>	42CrMo				
<b>Laser Hardening</b>	Yes				
<b>Black Oxidation</b>	Yes				

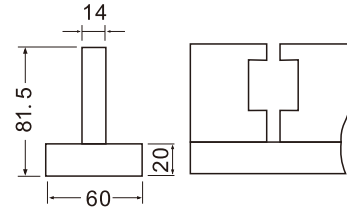
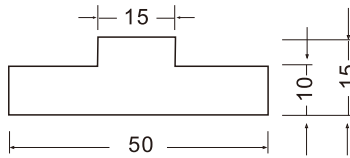

Config.	Length	Weight		V		Max Load
		kg	lbs	Width	Radius	
Non-sectioned	835mm/32.874"					
Sectioned						
Non-sectioned	415mm/16.339"					
Sectioned						
Customizable						
Material						
Laser Hardening						
Black Oxidation						

Config.	Length	Weight		V		Max Load
		kg	lbs	Width	Radius	
Non-sectioned	835mm/32.874"					
Sectioned						
Non-sectioned	415mm/16.339"					
Sectioned						
Customizable						
Material						
Laser Hardening						
Black Oxidation						

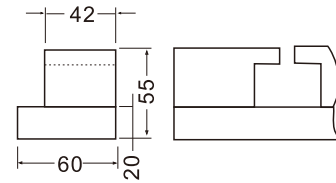
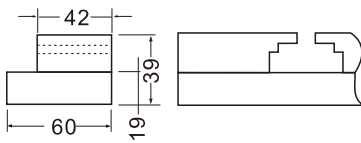

Config.	Length	Weight		V		Max Load
		kg	lbs	Width	Radius	
Non-sectioned	835mm/32.874"					
Sectioned						
Non-sectioned	415mm/16.339"					
Sectioned						
Customizable						
Material						
Laser Hardening						
Black Oxidation						

Config.	Length	Weight		V		Max Load
		kg	lbs	Width	Radius	
Non-sectioned	835mm/32.874"					
Sectioned						
Non-sectioned	415mm/16.339"					
Sectioned						
Customizable						
Material						
Laser Hardening						
Black Oxidation						

ACCESSORIES

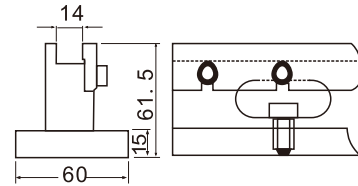
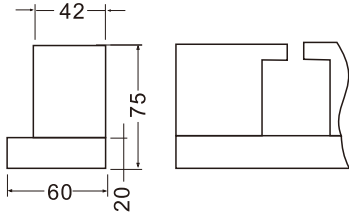

Config.	Length	Weight		V		Max Load
		kg	lbs	Width	Radius	
Non-sectioned	835mm/32.874"					
Sectioned						
Non-sectioned	415mm/16.339"					
Sectioned						
Customizable						
Material						
Laser Hardening						
Black Oxidation						

Config.	Length	Weight		V		Max Load
		kg	lbs	Width	Radius	
Non-sectioned	835mm/32.874"					
Sectioned						
Non-sectioned	415mm/16.339"					
Sectioned						
Customizable						
Material						
Laser Hardening						
Black Oxidation						

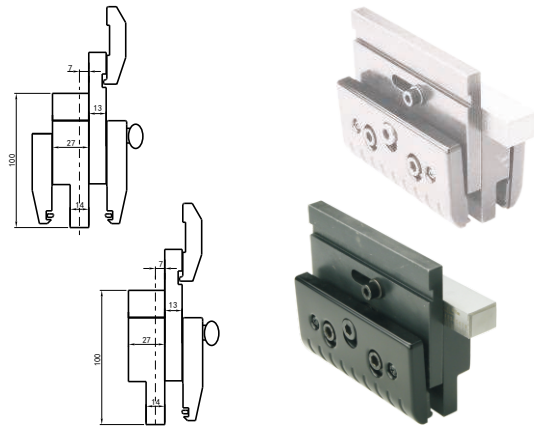
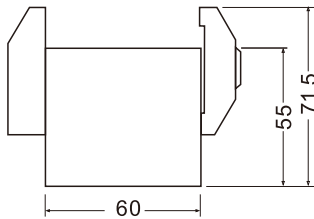

Config.	Length	Weight		V		Max Load
		kg	lbs	Width	Radius	
Non-sectioned						
Sectioned						
Non-sectioned						
Sectioned						
Customizable						
Material						
Laser Hardening						
Black Oxidation						

Config.	Length	Weight		V Angle		Max Load
		kg	lbs	Width	Radius	
Non-sectioned						
Sectioned						
Non-sectioned						
Sectioned						
Customizable						
Material						
Laser Hardening						
Black Oxidation						



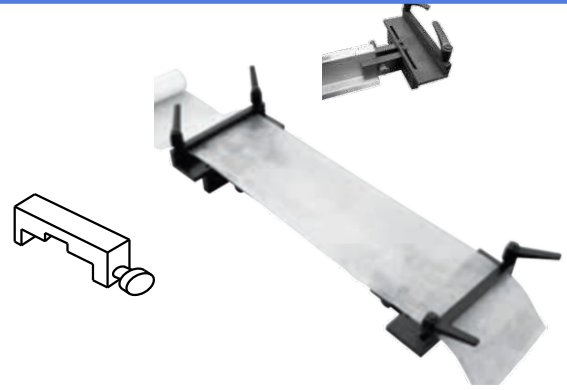
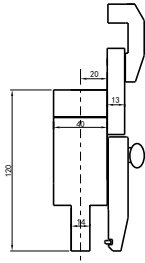
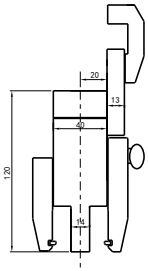

Config.	Length	Weight		V		Max Load
		kg	lbs	Width	Radius	
Non-sectioned						
Sectioned						
Non-sectioned						
Sectioned						
<b>Customizable</b>						
<b>Material</b>						
<b>Laser Hardening</b>						
<b>Black Oxidation</b>						

Config.	Length	Weight		V		Max Load
		kg	lbs	Width	Radius	
Non-sectioned						
Sectioned						
Non-sectioned						
Sectioned						
<b>Customizable</b>						
<b>Material</b>						
<b>Laser Hardening</b>						
<b>Black Oxidation</b>						

ACCESSORIES



# 1 Combination of Different Tooling Heights

## Euro Style Press Brake

By using different combinations, various cutting edge distances can be achieved to process different parts. Distance between the tip of the punch and die should not exceed half of the stroke minus the width of the V-groove.

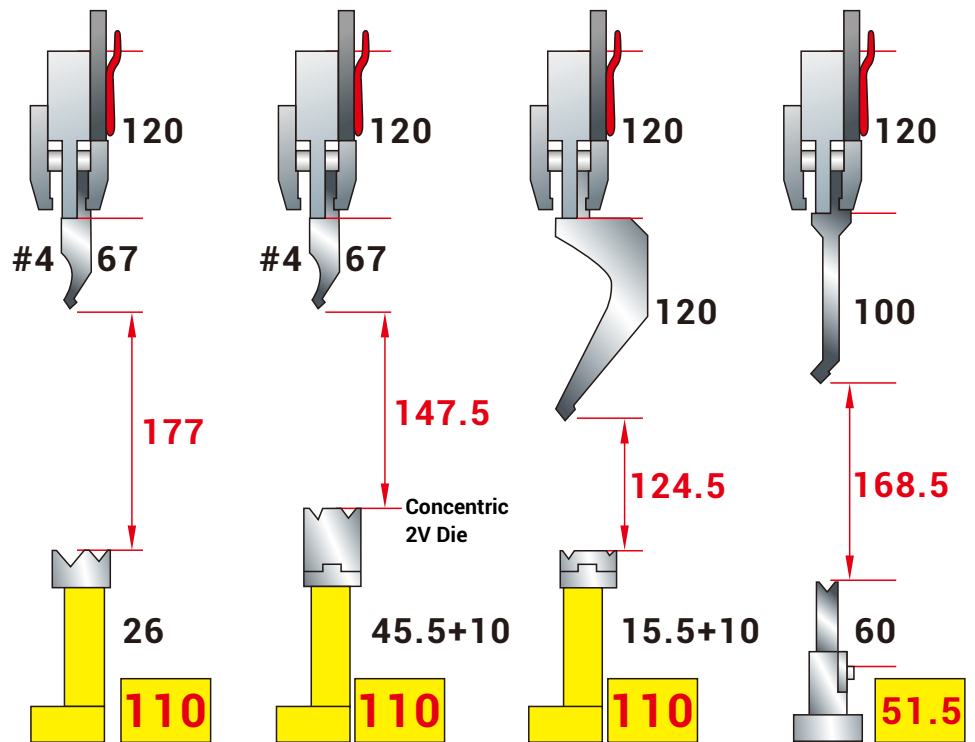

# 2 Tooling Storage

## Euro Style Press Brake

- 100\*74\*137 cm
- 1.01 CBM
- 209 KG



**KETEC Tooling cabinet for press brake**

## Die Opening Selection Formula

t	Gauge	12 or less	11-5/16"	3/8"-1/2"	3/8" and up
	Inches	0.105" or less	0.120"-0.313"	0.375"-0.500"	0.625" and up
"V" Size		6×t	8×t	10×t	12×t

If the above formulas are for reference only.

For more detailed information refer to the chart below.

If the material thickness and inside bend radius are known.

The following can be obtained from the chart below:

Pressure required for bending the material for 1 foot

Opening of the die to be used

Minimum bendable flange length

- t** Material thickness (tensile strength: 56892-71115 lbs/m<sup>2</sup>)
- F** Tons per one foot
- ir** Inside bend radius
- b** Minimum flange length
- v** Die opening

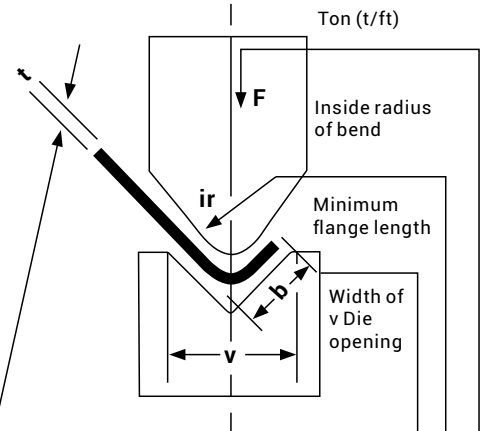

t		Thickness																			Mid Steel				
Gauge	Dec	4	6	7	8	10	12	14	16	18	20	25	32	40	50	63	80	100	100	160	200	250	mm	v	
		156	250	281	313	375	500	563	625	688	750	1,000	1.25	1,500	2,000	2,500	3,000	4,000	5,000	16,000	8,000	10,000	inches	b	
		.125	.188	.203	.219	.281	.344	.406	.438	.531	.563	.688	.875	1.125	1.375	1.750	2.188	2.188	3.500	14.500	5.500	6.875	inches	ir	
		031	031	047	047	063	078	094	109	125	141	156	203	250	313	406	516	625	750	11.031	1.313	1.625	inches		
20	0.036	5.4	3.6	3.0	2.5	2.0	1.7																		
18	0.048		6.8	5.8	4.8	3.7	2.7	2.4	2.0																
16	0.060				7.8	6.2	5.0	4.2	3.5	3.1	2.7														
14	0.075					11.0	8.2	7.0	5.5	4.8	4.1	3.1													
12	0.105						15.0	13.0	11.0	9.4	7.4	5.5	4.0												
11	0.120							16.0	13.0	10.0	7.3	5.0	3.8												
10	0.135									12.0	9.0	6.2	4.7	3.5											
188	0.180										24.0	15.0	11.0	7.5	5.7										
250	0.250											30.0	20.0	14.0	10.5	8.5									
313	0.313												36.0	25.0	18.0	13.0	10.0								
375	0.375													38.0	28.0	20.0	15.0	11.0							
500	0.500														52.0	39.0	30.0	22.0	16.0						
625	0.625															70.0	52.0	38.0	27.0	20.0	15.0				
750	0.750																	66.0	43.0	32.0	22.0				
1,000	1.000																		90.0	61.0	44.0				
1,250	1.250																				102.0	70.0			



# Precision Meets Perfection, Economical Solutions.

## < Phone number

North America  
+1 (339) 233-4347 (Charlie Qi)

China  
+86 (20) 37965500 (Christy Wen)  
+86 188-1981-5253 (Simon Tam)

## < WhatsApp

+1 518-837-1464 (North America)  
+86 188-1981-5253 (International)

## < Address

North America  
154 Wells Ave, Newton, MA, 02459, USA.

China  
No.7 Lifeng Road, Mingzhu Industrial Park, Conghua  
Guangzhou, China. 510931.

## < Email

North America  
Charlie.q@ketectooling.com

China  
International@ketectool.com  
Simon.t@ketectooling.com

## < Fax

+86 (20) 3796 5393

## < Follow us

LinkedIn

Facebook

Twitter